

**ariete**<sup>®</sup>

forever

Motorcycle Accessories  
2017  
#fullyArietized



MANUFACTURED IN ITALY  Since 1947



**π** anniversary  
1947-2017

# RUBBER: PLASTIC



SANDRO MENTASTI & C.  
s.a.s. - industria gomma - Varese



listino prezzi  
novembre 1982

ACCESSORI



RUBBER: PLASTIC

HISTORY



CATALOGO GENERALE

2

MANOPOLE



# 70 anni di storia

Benvenuti in Ariete. Da 70 anni la nostra Azienda è conosciuta ed apprezzata da motociclisti di tutto il mondo per l'alta qualità dei suoi prodotti, in gomma e materie plastiche. Il carattere familiare del Management, giunto alla terza generazione, continua con la stessa passione e determinazione del suo fondatore, Sandro Mentasti, che nel lontano 1947 ebbe l'idea di progettare, produrre ed offrire al Motociclista accessori e ricambi moto di altissima qualità.

Altissima qualità che in Ariete raggiungiamo con la Ricerca, a livello mondiale, orientata a pregiatissime materie prime poi elaborate con sofisticate tecnologie di produzione nel pieno rispetto dell'ambiente secondo il nostro disciplinare "Sandro Mentasti Environmental Protection Program".

Svolgiamo questa attività grazie al valore dei nostri preziosi ed esperti Collaboratori che con passione e dedizione esprimono l'esperienza acquisita e maturata dall'Azienda nei suoi 70 anni di storia e ci permettono di proporre ai mercati di tutto il mondo prodotti di alta gamma concepiti, realizzati, testati ed infine certificati in grado di soddisfare pienamente il Motociclista più esigente sia che si trovi in un percorso urbano, in pista, o nel più impervio sterrato off-road.

Questo Catalogo 2017, catalogo del 70°, è il focus sui prodotti di punta, oltre 800, del Programma Accessori Moto nel quale è racchiusa l'essenza di quello spirito vitale che esprime il "Made in Italy by Ariete". Buona lettura!

Ariete: evoluzione dell'esperienza made in Italy.

# 70 years of history

Welcome to Ariete. For over 70 years, our company has been responding to the needs of motorcyclists from all over the world by providing high quality rubber and plastic products. The family nature of our managerial staff, now in its third generation, continues with the same passion and determination as the founder, Sandro Mentasti, who in 1947 conceived the idea of designing and manufacturing high quality motorcycle accessories and spare parts for motorcyclists.

The high quality in Ariete is achieved by global research programs with a focus on high quality raw materials processed using sophisticated, environmentally friendly production technologies in accordance with our Sandro Mentasti Environmental Protection Program.

We work together with our passionate and dedicated expert partners who have gained experience in the company in its 70 years. This enables us to provide global markets with high-end products designed, manufactured, tested and certified that are able to fully satisfy the most demanding motorcyclist whether they are in an urban environment, on a racetrack, or on the most gruelling off-road dirt track.

The 2017, 70th anniversary Ariete catalogue, contains over 800 leading products in the Motorcycle Accessories Program and encapsulates the essence of the spirit of Made in Italy by Ariete. Enjoy your read!

Ariete: the evolution of Made in Italy experience.



# CONTENTS

## off-road

Ariete Experience	6
Goggles Optics Technology	8
Goggles AVS Ariete Ventilation System	11
07 Line AAA	12
07 Line Colors	14
Adrenaline Primis	16
Adrenaline Senior	18
Adrenaline Profi	20
Riding Crows Basic	22
Riding Crows Top	24
07 AAA Special Color	26
Adrenaline Primis Special Color	27
Ride And Roll Krew	28
Rally goggles	30
Enduro goggles	31
Snowmobile goggles	32
Tear-offs	34
Roll-off kit Standard	36
Roll-off BIG/XL on Adrenaline	38
Roll-off BIG/XL on Riding Crows	39
Roll-off kit BIG/XL	40
Goggles spare parts	42
Lenses Technology	44
Lenses	46
Off-Road grips Technology	48
Trinity Grips	50
Duality Grips	52
Unity Slimline Grips	54
Unity Half-Waffle Grips	55
Unity Half-Waffle ASP Grips	56
Extreme Grips	57
Various Off-road Grips	58
Accessories	60



## road

Ariete Vintage goggles	64
Road grips Technology	66
Aries Grips	68
Alu-Rub Grips	70
Alu-Rub Bar Weights	72
Estoril Grips	74
Standard Grips	75
Grips by brand	82
Vintage Style grips	89
Vitality Grips	90
Scooter Grips	91
Harri's Road	92
Harri's Tank protectors	93
Racing Valves	94

## technical parts

Ari	96
Brake Caliper Seal Kits	106
Master Cylinder Seal Kits	107
Fuel Pipes	109
Drive Belts by Gates	112
Merchandising	114
Ariete Limited Edition	118
Goggles Overview	120

## ESCLUSIONE DI RESPONSABILITÀ

I prodotti Ariete, Ari ed Harri's, pur essendo di altissima qualità, non possono prevenire danni in caso di impatto. Prima di utilizzare i prodotti Ariete, Ari ed Harri's Vi preghiamo di leggere attentamente le istruzioni fornite per l'uso ed il montaggio. La Sandro Mentasti Srl compie ogni sforzo al fine di assicurare che le informazioni contenute nel presente catalogo siano corrette e dettagliate, nonché di facile comprensione, ma declina ogni responsabilità per eventuali errori di interpretazione ed in caso di dubbi, anche in merito al montaggio e/o alle condizioni per l'uso, Vi invita a contattarla all'indirizzo e-mail: [info@ariete.com](mailto:info@ariete.com). In ogni caso, è esclusa la responsabilità della Sandro Mentasti Srl per eventuali danni a cose e/o persone occorsi durante l'uso dei prodotti nonché per eventuali danni derivanti da usi non corretti, speciali, eccezionali e/o comunque diversi da quelli cui il prodotto era stato originariamente destinato, da errori di montaggio e/o di installazione.

La Sandro Mentasti Srl realizza direttamente i propri prodotti, commercializzandoli con i marchi ARIETE, ARI ed HARRI'S. L'utilizzo, all'interno dei cataloghi, di eventuali codici originali di prodotti recanti marchi diversi da quelli summenzionati è da intendersi meramente descrittivo, così come l'eventuale utilizzo di marchi e/o denominazioni di altre case produttrici (a titolo esemplificativo, PIAGGIO®, HONDA®, YAMAHA®, SUZUKI®, KAWASAKI®, BMW®), cui la Sandro Mentasti Srl non è in alcun modo collegata. Tale utilizzo ha il solo fine di descrivere l'accessorio e/o il ricambio.

## EXCLUSION OF LIABILITY

*Ariete, Ari and Harri's products, while being of very high quality, may be subject to damage in case of impact or accident. Before using Ariete, Ari or Harri's products, please carefully read the instructions for use and installation. Sandro Mentasti Srl makes every effort to ensure that the information contained in this catalogue is correct and easy to understand, with some information specific to individual products, but accepts no responsibility for any misinterpretation. If you should require any further information, regarding assembly and/or conditions for use, please contact Sandro Mentasti Srl by e-mail at [info@ariete.com](mailto:info@ariete.com). In any event, Sandro Mentasti Srl is not liable for any damage to property and/or persons caused during the use of its products, and neither for any damage resulting from incorrect use and/or use other than that for which the product was originally intended, and damage resulting from assembly errors and/or incorrect installation.*

*Sandro Mentasti Srl manufactures its products directly, and markets them with the ARIETE, ARI and HARRI'S brands. The use contained within the catalogues of any original product codes bearing brands other than those mentioned above is intended as merely descriptive, as well as the possible use of trademarks and / or names of other manufacturers (for example, PIAGGIO®, HONDA®, YAMAHA®, SUZUKI®, KAWASAKI®, BMW®), which Sandro Mentasti Srl is in no way connected. The only purpose of this use is to describe the accessory and/or the part.*

## EXCLUSIÓN DE RESPONSABILIDAD

*Los productos Ariete, Ari y Harri's, incluso siendo de gran calidad, no pueden prevenir daños en caso de impacto. Antes de utilizar los productos Ariete, Ari y Harri's les rogamos que lean con atención las instrucciones de uso y montaje. La Sandro Mentasti Srl hace todo lo posible para asegurar que la información que contiene el presente catálogo sea correcta y detallada, así como de fácil comprensión, pero declina toda responsabilidad sobre posibles errores de interpretación; y, en caso de que tengan dudas sobre el montaje y/o condiciones de uso, les invita a ponerse en contacto con la dirección de correo electrónico: [info@ariete.com](mailto:info@ariete.com). En cualquier caso, se excluye la responsabilidad de la empresa Sandro Mentasti Srl sobre posibles daños a cosas y/o personas que pudieran ocurrir durante la utilización de los productos, así como sobre posibles daños derivados de una utilización incorrecta, especial o excepcional y/o, en cualquier caso, diferente del uso para el que el producto ha sido, en origen, destinado; tanto por errores de montaje como de instalación.*

*La empresa Sandro Mentasti Srl realiza directamente sus propios productos y los comercializa con la marca ARIETE, ARI & HARRI'S. La mención en el catálogo de posibles códigos originales de productos que lleven marcas y/o denominaciones de otras casas productoras distintas a las mencionadas, son meramente descriptivos, así como una posible mención de otras casas productoras (a título de ejemplo, PIAGGIO®, HONDA®, YAMAHA®, SUZUKI®, KAWASAKI®, BMW®), con las que la empresa Sandro Mentasti Srl no tiene ningún tipo de vínculo. Tal uso tiene como única finalidad describir el accesorio y/o recambio.*

DISCLAIMER

55

# EXPERIENCE

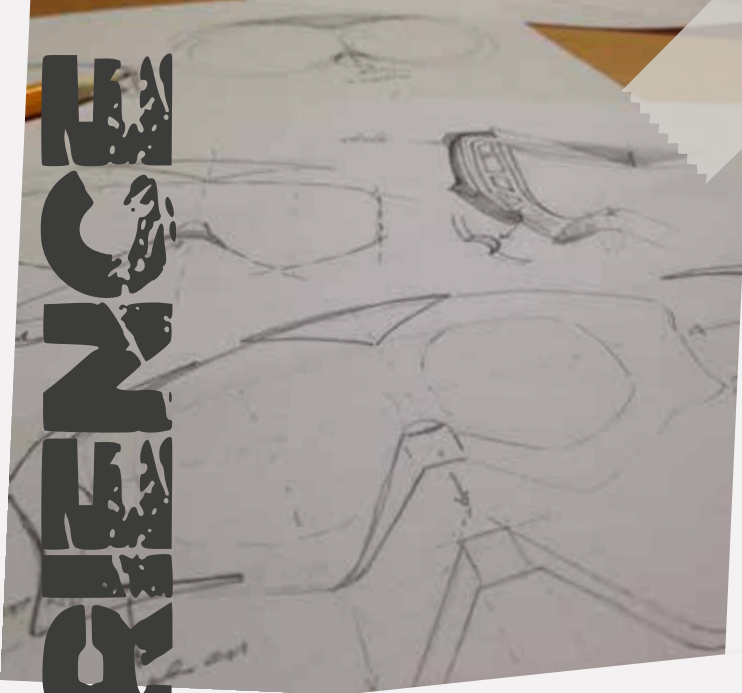

Design



Experience



Innovation



Research

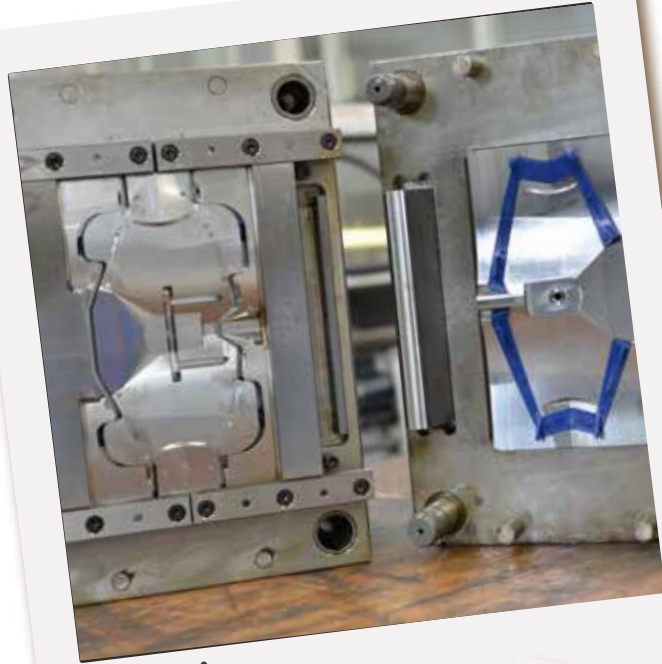

High  
Technology



Quality



Safety



Ergonomics



## Alta tecnologia

Per realizzare le proprie maschere Ariete si avvale delle tecnologie più avanzate per la produzione di ogni singolo componente. Sofisticata attrezzature permettono di raggiungere quell'alto standard qualitativo che pone le maschere Ariete al top del mercato mondiale.

## High technology

*Ariete goggle frames and ancillary components are made with the best technology available. The quality of the tooling ensures that the finish achieved is exemplary.*

## Alta tecnología

*Para la realización de las propias máscaras Ariete hace uso de la tecnología más avanzada para la producción de cada componente individual. Son los equipos sofisticados los que permiten alcanzar un alto nivel de calidad ubicando las máscaras Ariete en la cúspide del mercado mundial.*



## Materiali pregiati

Le materie prime impiegate sono frutto di meticolosa ricerca da parte di Ariete presso le più prestigiose industrie petrolchimiche nei vari continenti in modo da garantire la massima qualità dei materiali impiegati che si riscontra nelle maschere Ariete.

## Fine materials

*The search for new materials is never-ending. Ariete has for years worked with the world's best-known petro-chemical companies. The materials used are the result of research carried out by these companies, and are the best we can find.*

## Materiales nobles

*Las materias primas empleadas son fruto de una investigación minuciosa llevada a cabo por Ariete en las industrias petroquímicas de mayor prestigio en distintos continentes, de manera de asegurar la más alta calidad de los materiales aplicados en las máscaras Ariete.*



Photo D. Bologna

## Sviluppo nelle competizioni

Ogni progetto viene affinato con innumerevoli tests pratici da parte dei migliori Piloti dei campionati mondiali delle diverse discipline Off-Road. Tutti i suggerimenti dei Piloti vengono elaborati e trasferiti nella maschera finale che viene poi certificata dell'Ente Certificatore.

## Race-based development

*Each project is refined and tested by Ariete riders in relevant off-road world championship events. Rider feed-back is agreed and incorporated into the final design before this is submitted to the certifying authority for approval.*

## Progreso en las pruebas

*Cada proyecto se mejora con numerosas pruebas prácticas efectuadas por los más destacados Pilotos de los campeonatos mundiales de las diferentes disciplinas Off-Road. Todas las sugerencias de los Pilotos se procesan y se aplican a la máscara final, la que luego será certificada por la entidad correspondiente.*

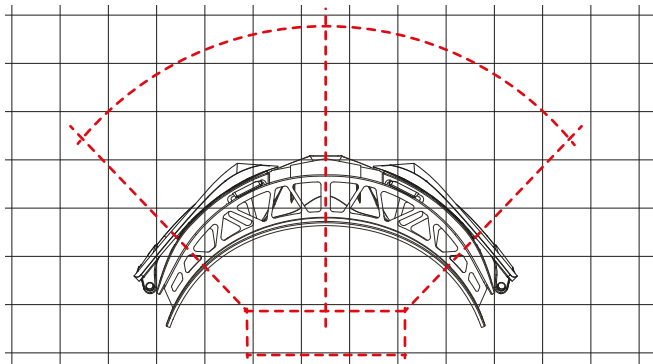

## Ampiezza campo visivo

I Tecnici Ariete hanno sviluppato un frame che permette un ampio campo visivo sia lateralmente che verticalmente consentendo al Pilota la massima visibilità dell'ambiente che lo circonda a tutto vantaggio della sicurezza. Le maschere Adrenaline e Riding Crows permettono l'uso di occhiali da vista (OTG)

## Field of vision

*Ariete technicians have developed a frame that allows a wide field of view both laterally and vertically. This feature makes a vital contribution to rider safety. Adrenaline and Riding Crows goggles are OTG – over the glasses models.*

## Campo de visión amplio

*Los técnicos de Ariete han desarrollado un marco que permite un amplio campo de visión, ya sea lateral como verticalmente, lo que consiente al Piloto la máxima visibilidad del ambiente que lo circunda en beneficio de su seguridad. Las gafas Adrenaline y Riding Crows permiten el uso con gafas correctivas (OTG).*



## Ergonomia & Design d'avanguardia

Il design delle maschere Ariete nasce dalle esigenze del Pilota nelle condizioni più estreme. I Tecnici Ariete hanno puntato sull'ergonomia del frame che si adatta perfettamente alla conformazione del viso. I materiali anallergici ed il Sistema di Ventilazione Ariete A.V.S. conferiscono alle maschere Ariete quelle doti di comodità ed affidabilità che le rende uniche.

## Ergonomics and avant-garde design

*the shape of Ariete goggle frames was born from experience under extreme conditions. Ariete technicians have focused on the ergonomics of the frame to ensure that it perfectly fits the rider's face. The hypoallergenic materials used and the Ariete Ventilation System (A.V.S.) make Ariete goggles uniquely comfortable.*

## Ergonomía y diseño de vanguardia

*El diseño de las máscaras Ariete nace de las exigencias del Piloto en condiciones extremas. Los técnicos de Ariete se han concentrado en la ergonomía del cuadro que se adapta perfectamente a la forma de la cara. Los materiales hipoalergénicos y el Sistema de Ventilación Ariete confieren a las máscaras Ariete esas cualidades de comodidad y fiabilidad que las hacen únicas.*



## Certificazioni & sicurezza

L'occhiale e le lenti Ariete sono certificati secondo le norme europee **EN 1938:2010**; le lenti sono provviste di trattamento anti-fog che è opzionale secondo la norma europea **EN 1938:2010**, superano i test di impatto "**High Mass**" e "**High velocity**" secondo la norma americana **ANSI Z87.1-2003** e rispondono alle caratteristiche prescritte dalla norma americana **VESC-8**. **Significa che la lente dell'occhiale ARIETE resiste all'impatto di una sfera d'acciaio di 6 mm di diametro lanciata a 216 km/h!**

## Safety & certifications

*Ariete goggles and lenses are certified according to European standards **EN 1938:2010**; they are provided with Anti-fog treatment, which is optional under European standard EN 1938:2010; they pass the "**High Mass**" and "**High velocity**" impact tests provided for by American **ANSI standard Z87.1-2003**; they meet the requirements of American standard **VESC-8**. **This means that the ARIETE lens will withstand a 6 mm. steel ball hitting it at 135 miles per hour!***

## Seguridad y certificaciones

*Las gafas y las lentes Ariete están certificadas conforme a las normas europeas **EN 1938:2010**; las lentes están provistas de tratamiento anti-empañamiento opcional en la norma europea EN 1938:2010, superan los controles de impacto "**High Mass**" y "**High velocity**" conforme a la norma americana **ANSI Z87.1-2003** y responden a las características prescritas por la norma americana **VESC-8**. **Significa que la lente ARIETE resiste a una esfera de acero de 6mm. de diámetro que impacta a 216 km/h!***



Small - Tight comfort - Compact structure

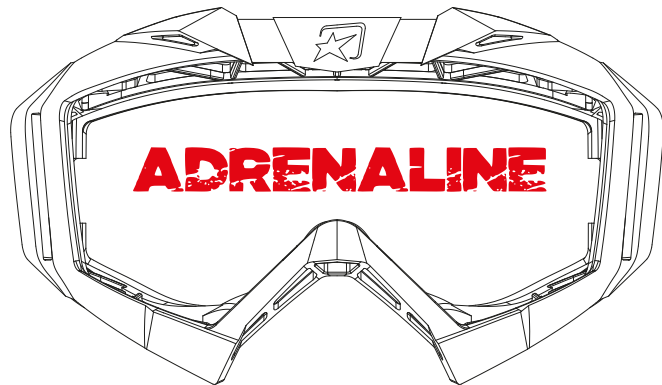

Medium - OTG (Over The Glasses) Design  
Extra Ventilation - Compatible with BIG/XL Roll-off Kit

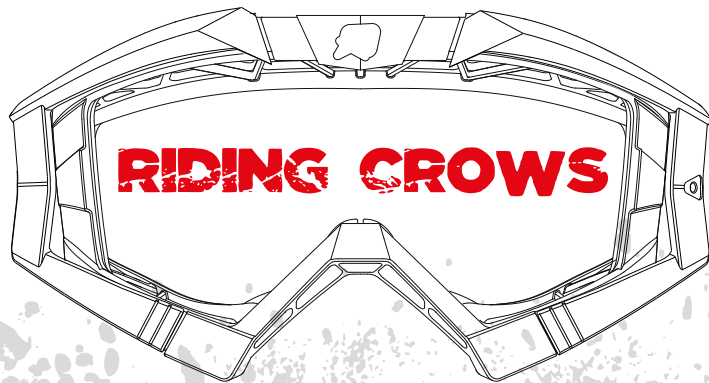

Medium/Large - OTG (Over The Glasses) Design  
3D Thermoformed Foam For Improved Fit  
Asian Fit Foam Available - Adjustable Outriggers For Perfect Helmet  
Fit - Compatible with BIG/XL Roll-off Kit

# ONE LENS FITS ALL ARIETE GOGGLES

UV rays total protection

Best Anti fog coating

Distortion-free

Top Lexan® lenses

AVS Ariete Ventilation System

Tough PUR frame

Hypo-allergenic foams  
in contact with the skin

Elastic strap with anti-slip silicone bead

Double buckle for quick adjustment

Safety and Certifications

all models are CE-approved

# A.V.S. ARIETE VENTILATION SYSTEM



**1** GOGGLES VENTILATION SYSTEM

AAA

LINEA



12960-ARED

FO



12



12960-ABIA



12960-ANER



12960-ABLU



12960-ALIM



12960-AORA

### Features

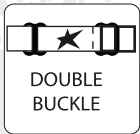
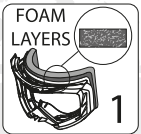
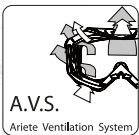

### Optional Accessories



**COLORS**

**LINE**



12960-CAGR

**FO**



**14**



12960-COBA



12960-CARB



12960-CBGR



12960-CNBG

## Features

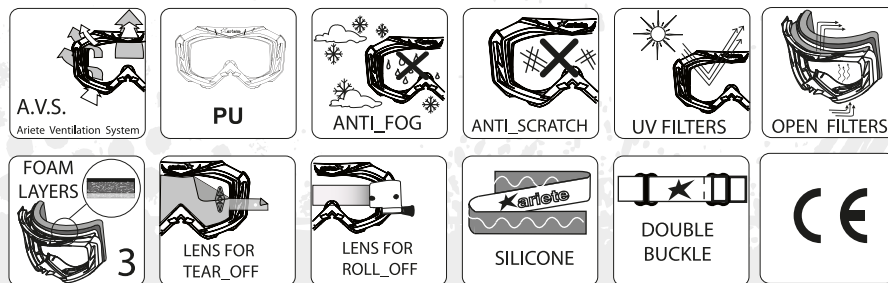

## Optional Accessories



**PRIMIS**

**ADRENALINE**

**10**



14001-PRO





14001-PRA



14001-PRL



14001-PRR



14001-PRN



14001-PRB

## Features

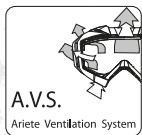

A.V.S.  
Ariete Ventilation System

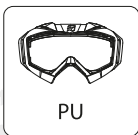

PU



ANTI\_FOG



ANTI\_SCRATCH

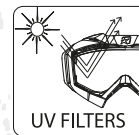

UV FILTERS



OPEN FILTERS

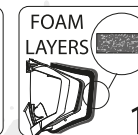

FOAM LAYERS  
1



O.T.G.  
Over The Glasses

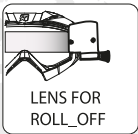

LENS FOR  
ROLL\_OFF



LENS FOR  
TEAR\_OFF



SILICONE

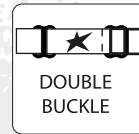

DOUBLE  
BUCKLE



CE

## Optional Accessories

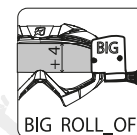

BIG  
ROLL\_OFF

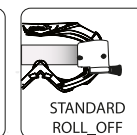

STANDARD  
ROLL\_OFF



One Size Fits All  
ARIETE LENS



**SENIOR**

**ADRENALINE**



14001-SAAB



**10**

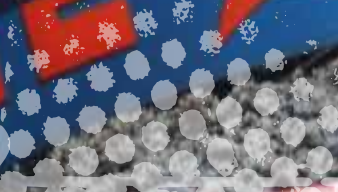



14001-SRRA



14001-SOOB



14001-SBGG



14001-SNNG

## Features

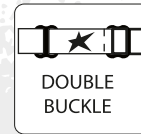
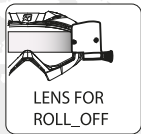
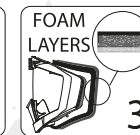
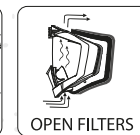
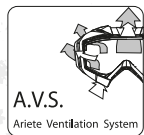

## Optional Accessories

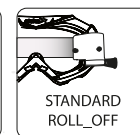
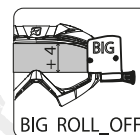

**PROFI**

**ADRENALINE**



14001-POAB



20



14001-PGAR



14001-PAAO



14001-PBBN



14001-PNGB

SPECIAL  
FOAM



CARBON

## Features

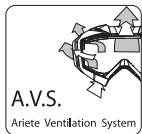

A.V.S.  
Ariete Ventilation System

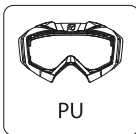

PU



ANTI\_FOG



ANTI\_SCRATCH

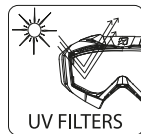

UV FILTERS



OPEN FILTERS

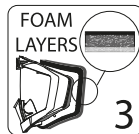

FOAM LAYERS  
3



O.T.G.  
Over The Glasses

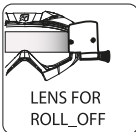

LENS FOR  
ROLL\_OFF



LENS FOR  
TEAR\_OFF



SILICONE

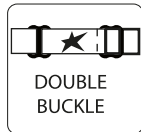

DOUBLE  
BUCKLE

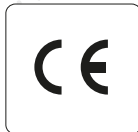

CE



MICROFIBER  
BAG  
INCLUDED

## Optional Accessories

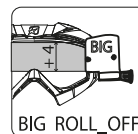

BIG  
ROLL\_OFF

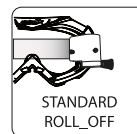

STANDARD  
ROLL\_OFF

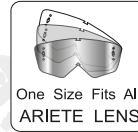

One Size Fits All  
ARIETE LENS



**BASIC**

**SMOCS**



13950-BRGG

13953-BRGG ASIAN FITTING FOAM

**RIDING**

22





13950-BNNG

13953-BNNG ASIAN FITTING FOAM



13950-ABAB

13953-ABAB ASIAN FITTING FOAM



13950-RBRA

13953-RBRA ASIAN FITTING FOAM



13950-OB0B

13953-OB0B ASIAN FITTING FOAM

## Features

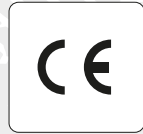
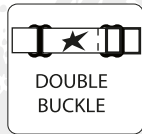
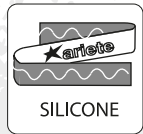
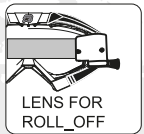
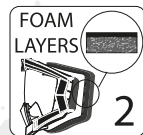
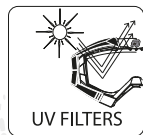
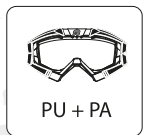
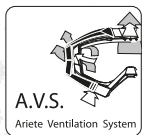

## Optional Accessories

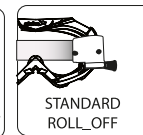
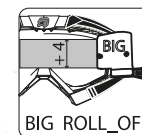

# SMOCS CROW'S TOP



13950-TBVG

13953-TBVG ASIAN FITTING FOAM

# FRIDING SMOCS CROW'S TOP





**13950-TBGF**  
**13953-TBGF** ASIAN FITTING FOAM



**13950-TNVF**  
**13953-TNVF** ASIAN FITTING FOAM



**13950-TGFO**  
**13953-TGFO** ASIAN FITTING FOAM



**13950-TAOF**  
**13953-TAOF** ASIAN FITTING FOAM

### Features

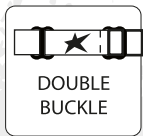
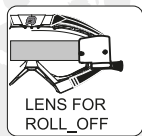
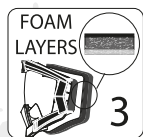
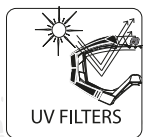
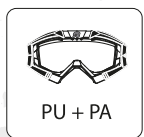
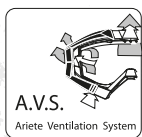

### Optional Accessories

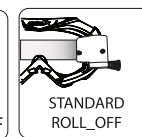
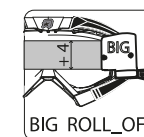

# AAA MULTI-LAYER

W  
N  
T  
O



12960-ANAA



12960-ANOR

## Features

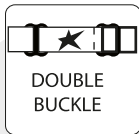
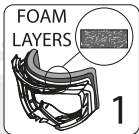
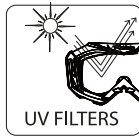
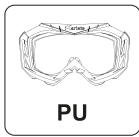
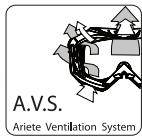

## Optional Accessories



# PRIMIS MULTI-LAYER

# ADRENALINE



14001-PNOV



14001-PNVA

## Features

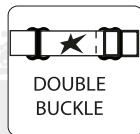
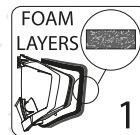
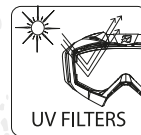
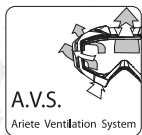

## Optional Accessories



# GOOGLES

**KREW**

**20 RIDE AND ROLL**



13950-RRKB  
13953-RRKB ASIAN FITTING FOAM  
FEATURES RIDING CROWS TOP





X Games 2016  
Massimo Bianconcini  
Photo M. Cannizzaro



RIDE AND ROLL KREW

# ADRENALINE

RALLY



14001-DN

## Adrenaline Features

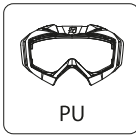

# RIDING CROWS



13950-DNN

## Riding Crows Features

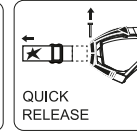
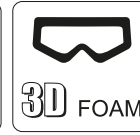
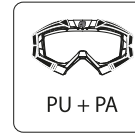

## Optional Accessories



## Common features

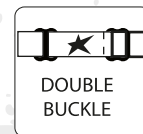
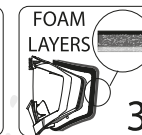
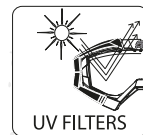
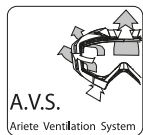

## Common Optional Accessories



# ADRENALINE



14001-EN

## Adrenaline Features

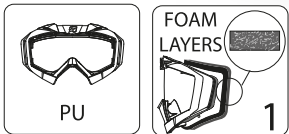

# RIDING CROWS



13950-ENB

13953-ENB  
ASIAN FITTING FOAM

## Riding Crows Features

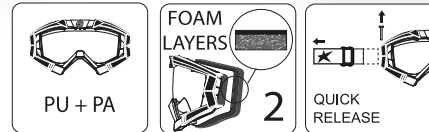

## Optional Accessories



## Common features

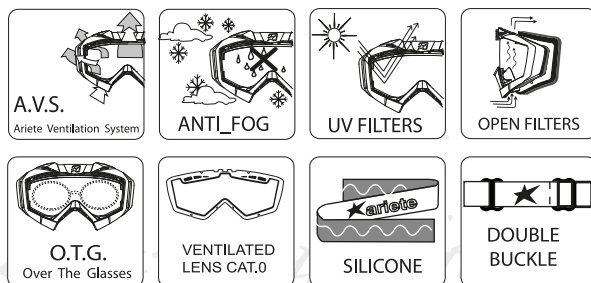

## Common Optional Accessories















ORIGINAL

# ADRENALINE

SNOWMOBILE

32

## Features

 <p>A.V.S. Ariete Ventilation System</p>	 <p>PU</p>	 <p>ANTI_FOG</p>	 <p>ANTI_SCRATCH</p>
 <p>CLOSED FILTERS</p>	 <p>UV FILTERS</p>	 <p>FOAM LAYERS 1</p>	 <p>O.T.G. Over The Glasses</p>
 <p>VENTILATED LENS CAT.0</p>	 <p>EXTRA FOAM</p>	 <p>SILICONE</p>	 <p>DOUBLE BUCKLE</p>

## Optional Accessories

 <p>One Size Fits All ARIETE LENS</p>
--



14001-MB15



# RIDING CROWS



13950-MM15



13950-MT15

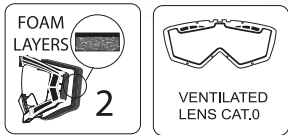

Spugna maggiorata  
Extra-thick foam  
Espuma sobredimensionada

## Common features

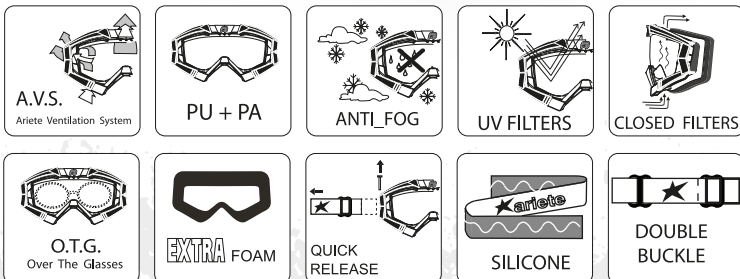

## Common Optional Accessories



SNOWMOBILE

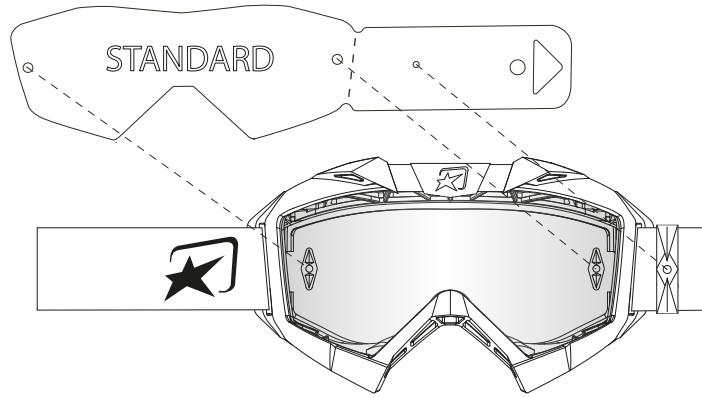

## STANDARD

12964-TOLE

Kit 5 pacchetti, 6 Tear-offs/pacchetto. Lenti a strappo standard da applicare sulla lente.

*Kit 5 stacks, 6 Tear-offs/stack Standard tear-offs to place on the lenses.*

*Kit 5 paquetes, 6 Tear-offs/paquete. Tirables estandard para utilizar sobre la lente.*

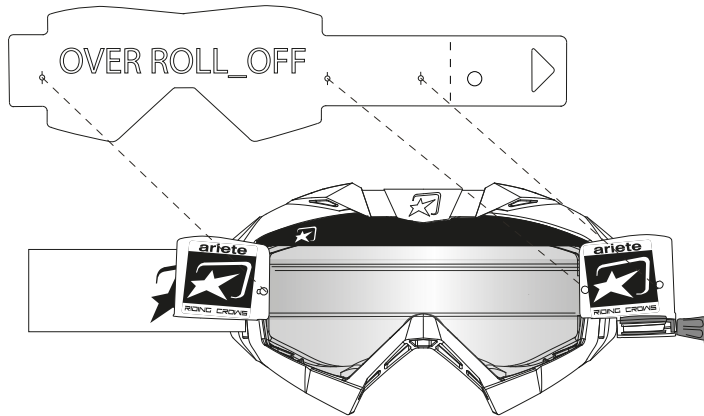

## SUITABLE FOR ROLL-OFF STANDARD ROLL-OFF AND BIG/XL ROLL-OFF

12964-TORO

Kit 3 pacchetti, 6 Tear-offs/pacchetto. Lenti a strappo specifiche da applicare sul Roll-off.

*Kit 3 stacks, 6 Tear-offs/stack. Specific tear-offs to place on the Roll-off system.*

*Kit 3 paquetes, 6 Tear-offs/paquete. Tirables específicos para aplicar sobre el Roll-off.*

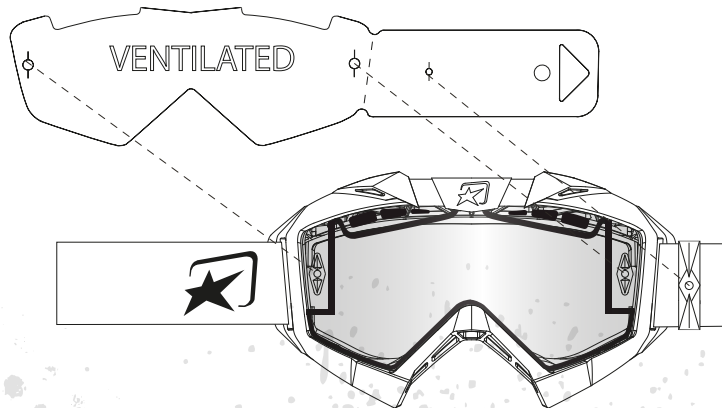

## SUITABLE FOR VENTILATED LENSES

12964-TOV

Kit 3 pacchetti, 6 Tear-offs/pacchetto. Lenti a strappo specifiche da applicare su lenti ventilate.

*Kit 3 stacks, 6 Tear-offs/stack. Specific tear-offs to place on ventilated lenses.*

*Kit 3 paquetes, 6 Tear-offs/paquete. Tirables específicos para aplicar sobre lentes ventiladas.*

# LAMINATED RECOMMENDED FOR RACE

**12964-TOLL** *Patented technology by Racing Optics® USA*

Kit 3 pacchetti, 7 Tear-offs/pacchetto. I tearoffs laminati sono 7 lenti a strappo "sigillate" tra loro.

Kit 3 stacks, 7 Tear-offs/stack. Mount 7 layers at one time and stack up to 21 tear-offs.

Kit 3 paquetes, 7 Tear-offs/paquete. Los tearoffs laminados son 7 películas desechables selladas entre sí, que puedes montar hasta 3 kits.

# TEAR-OFF RACING PINS

**12964-RE**

Clips eccentriche regolabili per tear-offs. Tendono al massimo la lente a strappo evitando che polvere e sporco si infilino tra il tear-off e la lente, vendute a paio; uso professionale.

*Eccentric pins for precise tear-off adjustment to avoid dust between lens and tearoff, sold in pairs, professional use.*

*Clips regulables para tender al máximo el tear-off evitando que el polvo y la suciedad se introduzcan entre la lente removible y el cristal, se venden por pares, uso profesional.*

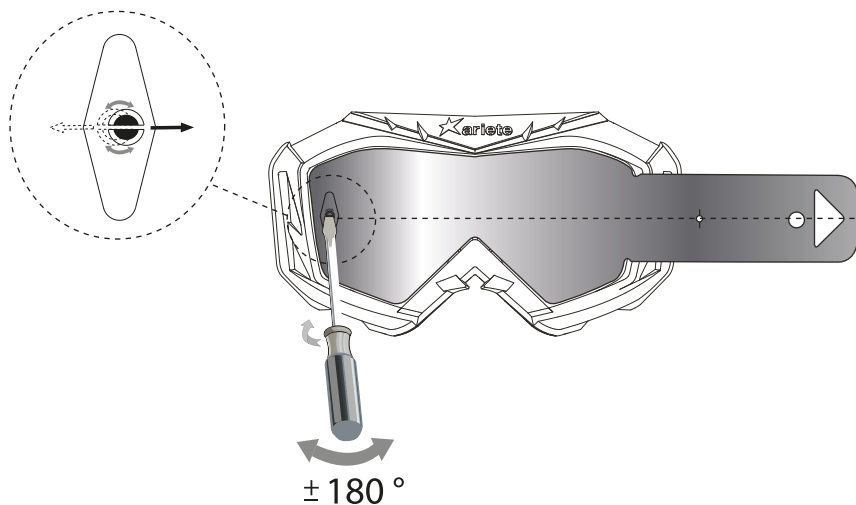
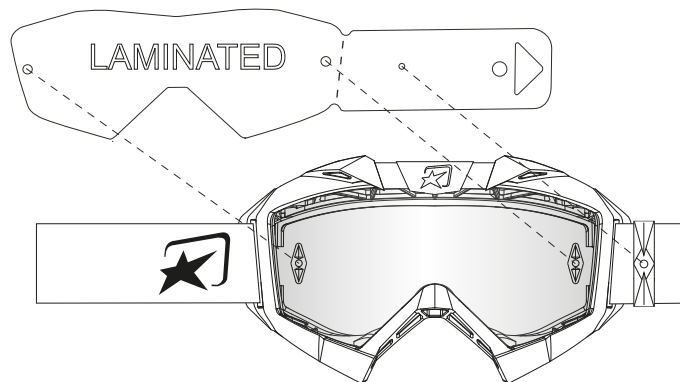

TEAR-OFFS

# STANDARD

# ROLL-OFF



## Assembled Lens Standard Roll-Off 12961-KRO

- 1 lente / lens / lente cod.12961-PCCH
- 2 canistri premontati / assembled canisters / contenedores puestos
- 2 rullini / rolls of film / rollos de película transparente
- 1 guida di scorrimento / 1 anti-stick slide rail / carril transparente
- 1 mud flap
- 6 Tear-offs for Roll-Off gratis / for free / sin cargo

## APPLICATIONS

✓ **ADRENALINE**

✓ **RIDING CROWS**

✓ **07 LINE**



36

# STANDARD



## Kit Standard Roll-Off 12962-RO

- 2 canistri / canisters / contenedores
- 2 rullini / rolls of film / rollos de película transparente
- 1 guida di scorrimento / 1 anti-stick slide rail / carril trasparente
- 1 mud flap



# SPARE PARTS



12963-MF 3 pcs.



12967 3 pcs.

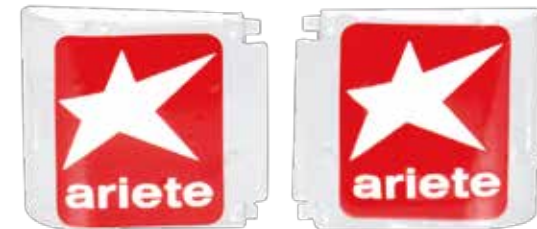

12962-CORO 2 pcs.



12962-KRU 6 pcs.

ROLL-OFF KIT

# BIG/XL

# ROLL-OFF ADRENALINE



14001-NROB

## Features

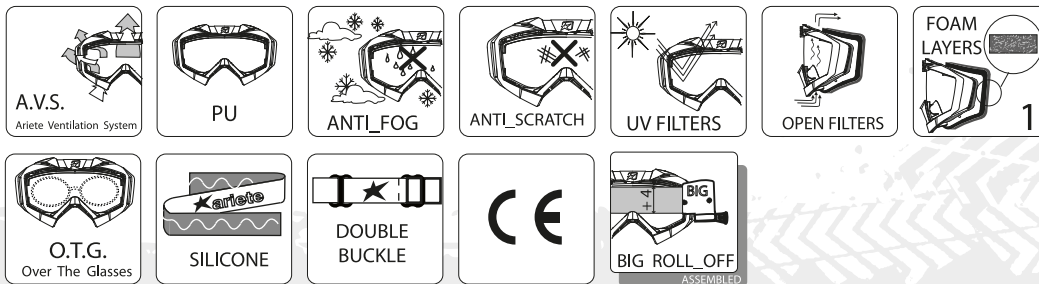

## Optional Accessories



30

**BIG / XL**

# ROLL-OFF RIDING CROWS



13950-NNRO

13953-NNRO ASIAN FITTING FOAM

## Features

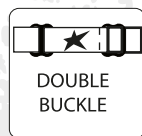
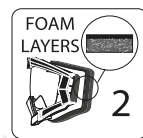
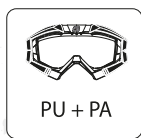
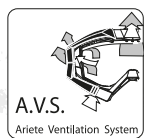

## Optional Accessories



# BIG / XL

# ROLL-OFF



### Assembled Lens BIG/XL Roll-Off 12961-RCRO

- 1 lente per BIG/XL Roll-Off / lens / lente cod.12961-RCFR
- 2 canistri premontati / assembled canisters / contenedores puestos
- 2 rullini / rolls of film / rollos de película transparente
- 1 guida di scorrimento / 1 anti-stick slide rail / carril trasparente
- 1 mud flap
- 6 Tear-offs for Roll-Off gratis / for free / sin cargo

## APPLICATIONS

✓ ADRENALINE

✓ RIDING CROWS

✗ 07 LINE

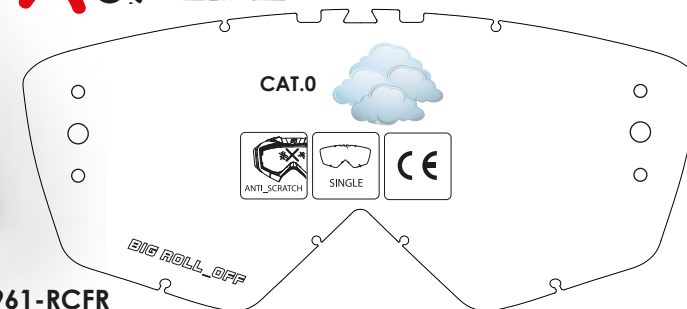

**12961-RCFR**

Lens for BIG Roll-Off



## Kit BIG/XL Roll-Off 12962-RCRO

- 2 canistri / canisters / contenedores
- 2 rullini / rolls of film / rollos de película transparente
- 1 guida di scorrimento / 1 anti-stick slide rail / carril trasparente
- 1 mud flap

**BIG/XL**



## **SPARE PARTS**



12963-RCMF 3 pcs.

**+4 mm.**



12962-RCRU 6 pcs.



12967-RC 3 pcs.

**BIG ROLL-OFF KIT**

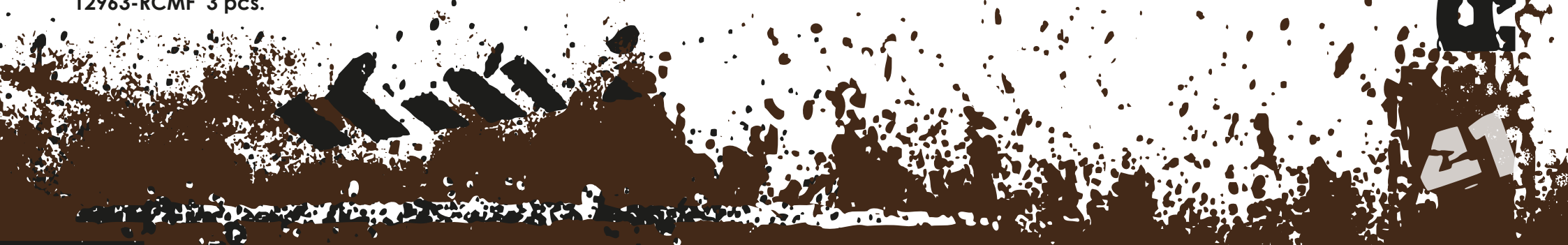

# RIDING CROWS

# SPARE PARTS

Paio ricambio chele per fissaggio elastico, un paio di perni incluso

Spare QD outriggers for head-band attachment, pair of pins included

Juego recambio garras para la tracción del elástico, un juego de enganches incluido



**13952**

Ricambio 4 perni per elastico  
4 spare pins for QD outriggers  
4 enganches de recambio para garras



**13951-TGFL**

FLUO COLOR

FLUO COLOR



**13951-GLF**



**13951-OLF**



**13951-TGFV**



**13951-B**



**13951-N**



**13951-R**



**13951-A**

# RIDING CROWS



**12966-RC**

Paranaso - Noseguard - Cubrenariz



**12966-N**

Paranaso - Nose Guard - Cubrenariz



**12966-HM**

Paranaso mezza maschera  
Half mask  
Cubrenariz completo

**07 LINE**

**SPARE PARTS**



LENSES

TECHNOLOGY

RA



Ivan Cervantes - Photo D.Agrafi

# LENSES

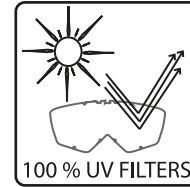

#ariete\_best\_eye\_protection  
#one\_lens\_fits\_all\_ariete\_goggles

#distorsion\_free

#ariete\_impact\_protection

#ariete\_best\_antifog



# TECHNOLOGY























# LENSES

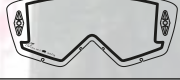

CAT. 0

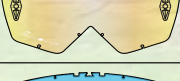
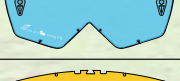

CAT. 1

			 SINGLE	 DOUBLE	 100 % UV FILTERS	 NO FOG	 ANTI_SCRATCH	 VENTILATED	 LENS FOR STANDARD ROLL_OFF	 LENS FOR TEAR_OFF	 One Size Fits All ARIETE FRAMES	 MULTILAYERS TREATMENT	 MIRRORED	 CE
CLEAR AIR		12961-PCCH	✓		✓	✓	✓		✓	✓	✓			✓
CLEAR AIR		12961-SCCH	✓		✓	✓	✓				✓			✓
CLEAR AIR		12961-RCFR	✓		✓	✓	✓	FOR BIG/XL ROLL-OFF ONLY FOR ADRENALINE/RIDING CROWS ONLY					✓	
CLEAR AIR		12961-DCC		✓	✓	✓	✓		✓	✓	✓			
CLEAR AIR		12961-DCVC		✓	✓	✓	✓	✓	✓	✓	✓			
CLEAR AIR		12961-DCV		✓	✓	✓	✓	✓			✓			
CLEAR AIR		12961-DCHL		✓	✓	✓	✓				✓			
MULTI LAYER RAINBOW		12961-MUAZ	✓		✓	✓			✓	✓	✓	✓		✓
BLUE SKY		12961-PCAZ	✓		✓	✓	✓		✓	✓	✓			✓
YELLOW DESERT		12961-PCG	✓		✓	✓	✓		✓	✓	✓			✓
YELLOW DESERT		12961-DCGV		✓	✓	✓	✓	✓			✓			
LIGHT CORAL		12961-PCAR	✓		✓	✓	✓		✓	✓	✓			✓
LIGHT CORAL		12961-DCOC		✓	✓	✓	✓	✓	✓	✓	✓			

# LENSES

SINGLE	DOUBLE	100% UV FILTERS	NO FOG	ANTI_SCRATCH	VENTILATED	LENS FOR STANDARD ROLL-OFF	LENS FOR TEAR-OFF	One Size Fits All ARIETE FRAMES	MULTILAYERS TREATMENT	MIRRORED	CE
--------	--------	-----------------	--------	--------------	------------	----------------------------	-------------------	---------------------------------	-----------------------	----------	----



CAT. 1

LIGHT CORAL  12961-DCOV

BLUE CREEK  12961-PCFA

BLUE CREEK  12961-DCFA

GREEN MUSK  12961-PCVS

SILVER CHROME  12961-PCSP

SILVER CHROME  12961-SCSC

SILVER CHROME  12961-DCSV

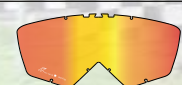

CAT. 2

MULTILAYER RED  12961-MLR

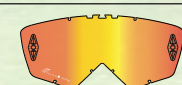
MULTILAYER RED  12961-MLRC

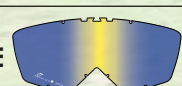
MULTILAYER BLUE  12961-MLA

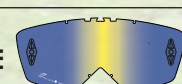
MULTILAYER BLUE  12961-MLAC



CAT. 3

SILVER CHROME  12961-SCST

SILVER CHROME  12961-DCST

MULTI LAYER  12961-DMLR

	✓	✓	✓	✓	✓			✓			
✓		✓	✓	✓		✓	✓	✓			✓
	✓	✓	✓	✓	✓			✓			
✓		✓	✓	✓		✓	✓	✓			✓
✓		✓	✓			✓	✓	✓		✓	✓
✓	✓	✓	✓					✓		✓	
✓	✓	✓	✓		✓			✓	✓		
✓		✓	✓					✓	✓		
✓	✓	✓	✓		✓			✓		✓	
	✓	✓	✓		✓			✓	✓		✓

**OFF ROAD GRIPS**

**TECHNOLOGY  
IS  
CONTACT**



# OFF ROAD GRIPS

TECHNOLOGY

49

palm in legendary supersoft,  
critical finger-grip area with half-waffle surface

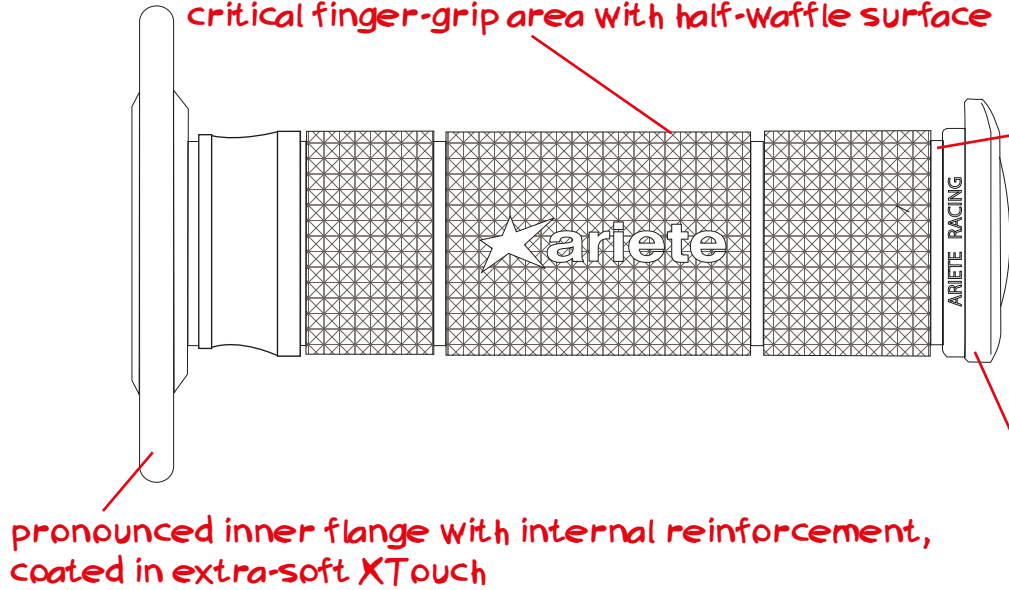

the fourth groove is situated at the extreme outer end of the grip to prevent grit from being trapped between bar and grip or bar and twist grip when used with hand guards

outer flange pre-marked for piercing with a cutting guide for use with all-round hand guards

pronounced inner flange with internal reinforcement, coated in extra-soft XTouch

anatomically profiled channel on the right side for thumb and forefinger

**HALF-WAFFLE SHAPE**

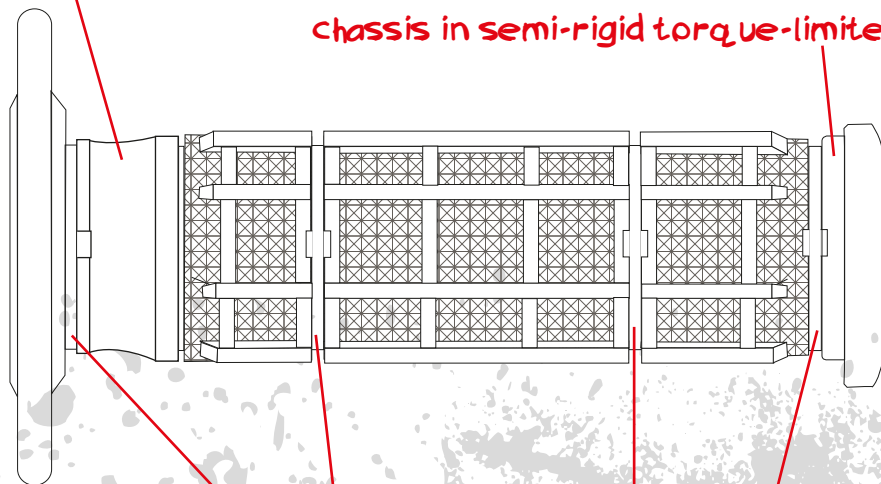

chassis in semi-rigid torque-limited elastomer

four grooves for steel wire give extra security

**GRIPS**

**TRINITY**

115 mm - 4 1/2"  
0 1 2 3 4 5 6 7 8 9 10 11

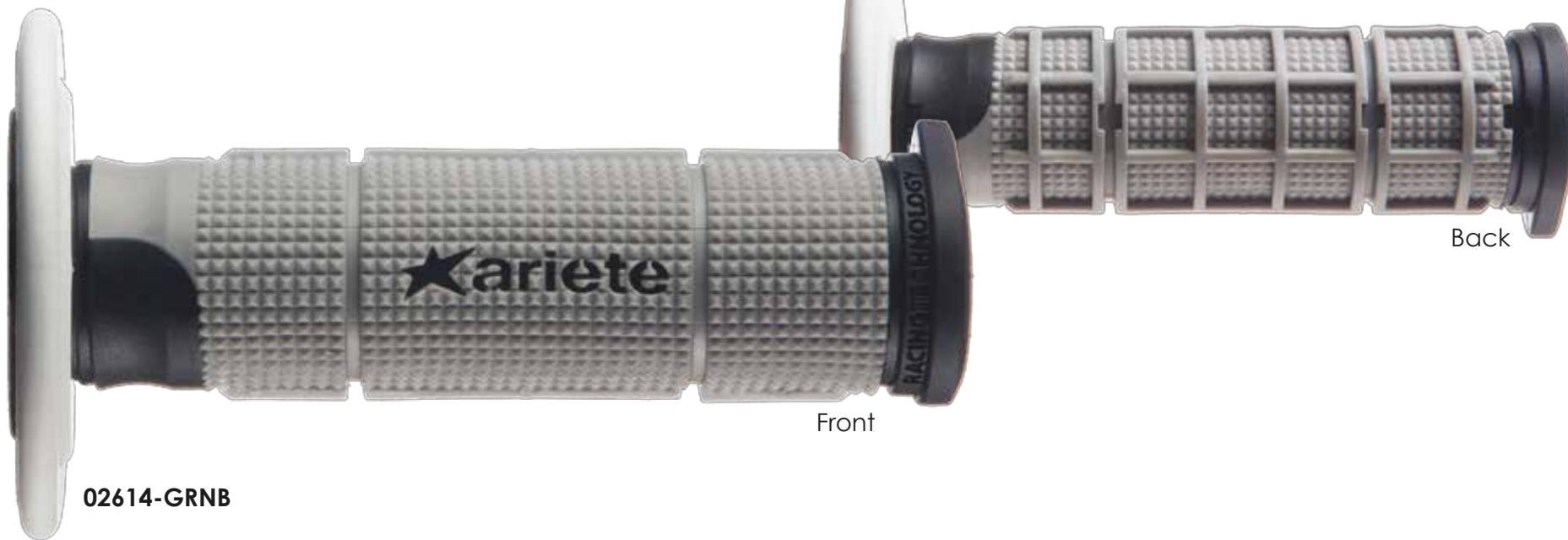

02614-GRNB



**50**



02614-GRRN



02614-GRAR



02614-BNR



02614-GRAN

## Features

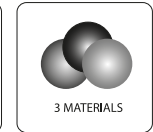

# DUALITY GRIPS

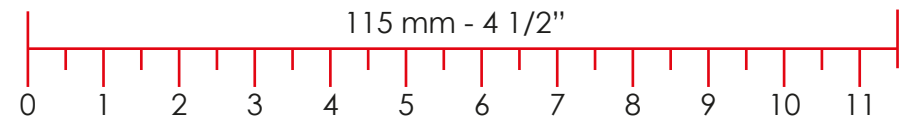

Front

Back

02629-NG

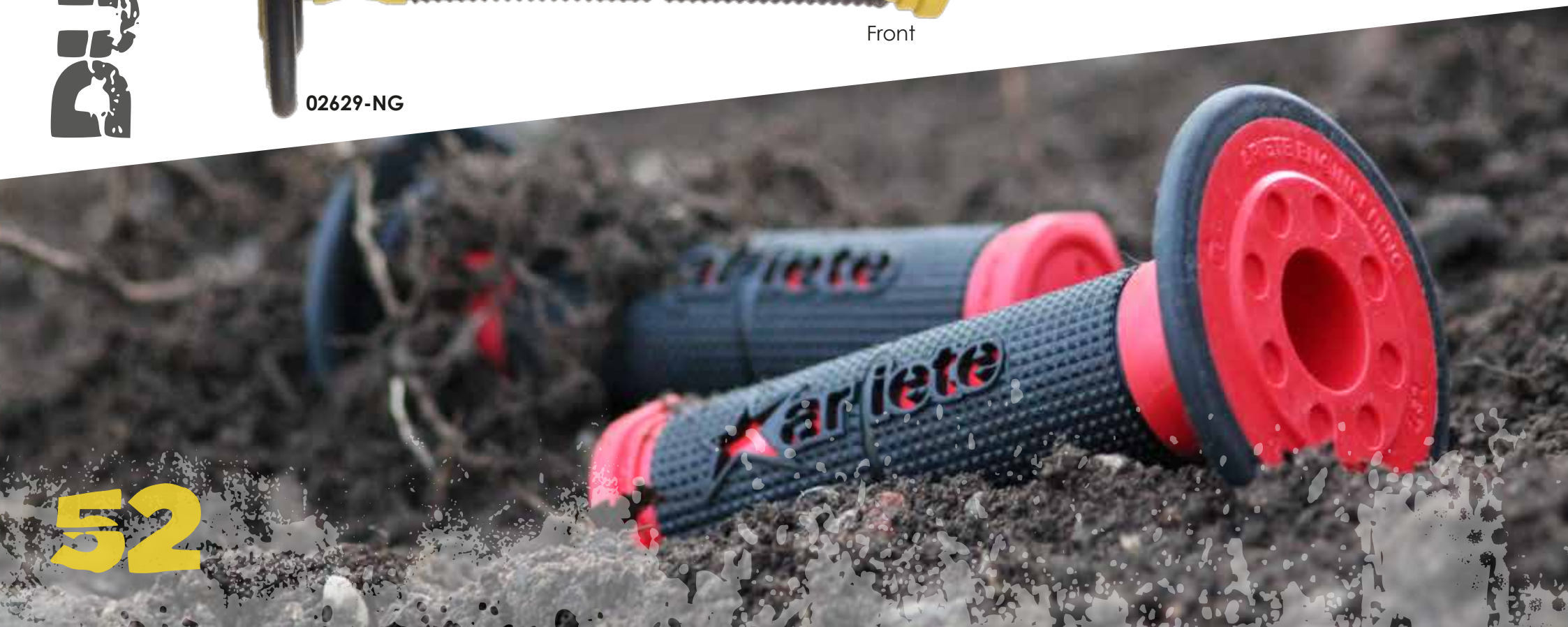



02629-NA



02629-NR



02629-NAR



02629-GRN

## Features

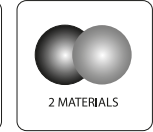

# GRIPS

# INFINITY SLIMLINE

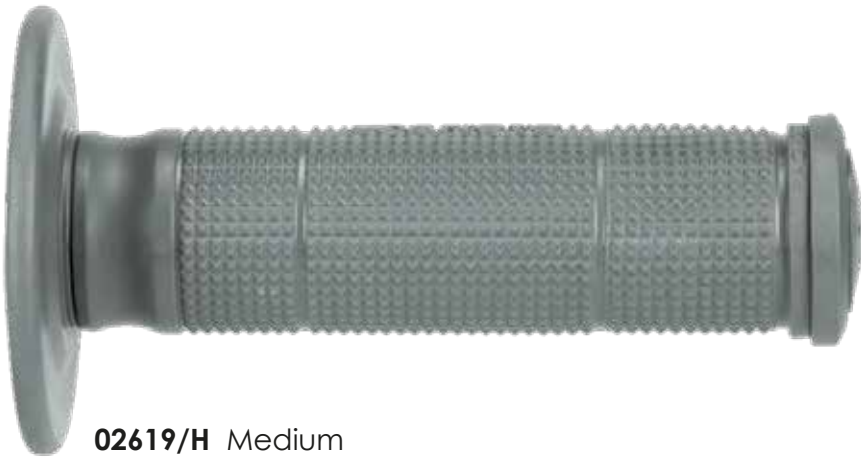

02619/H Medium

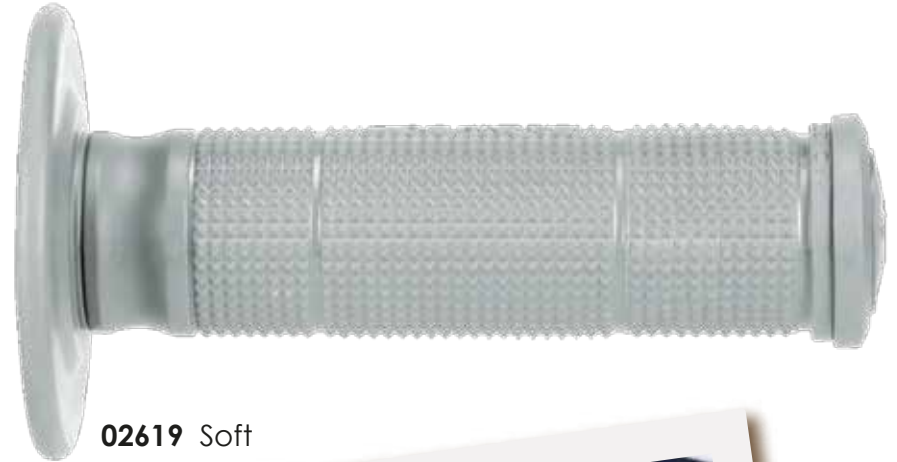
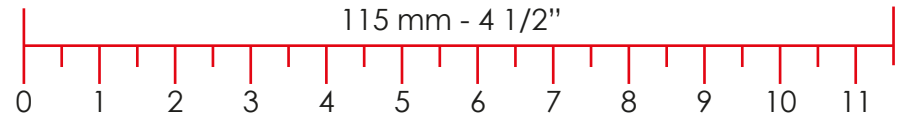

02619 Soft



02619-N Soft

## Features

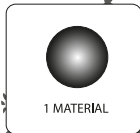

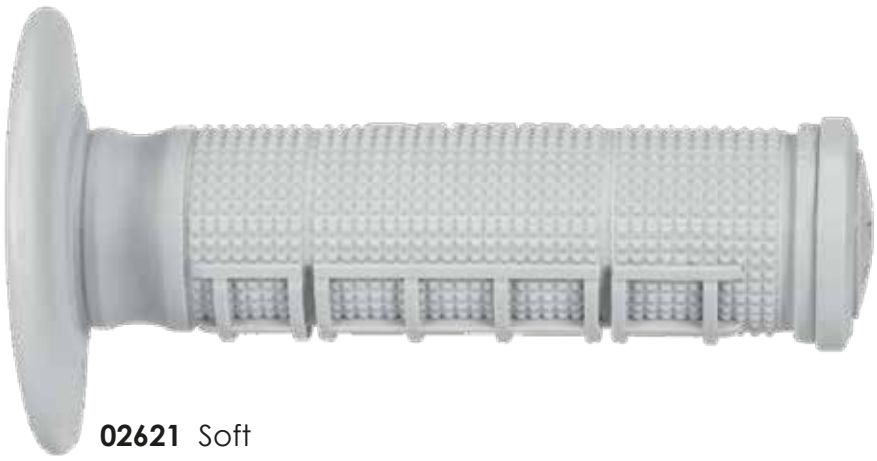
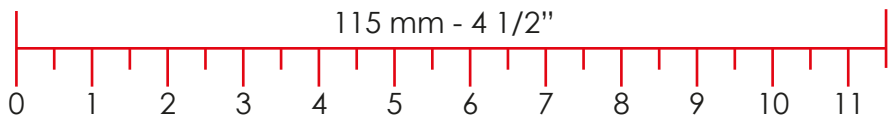

02621 Soft

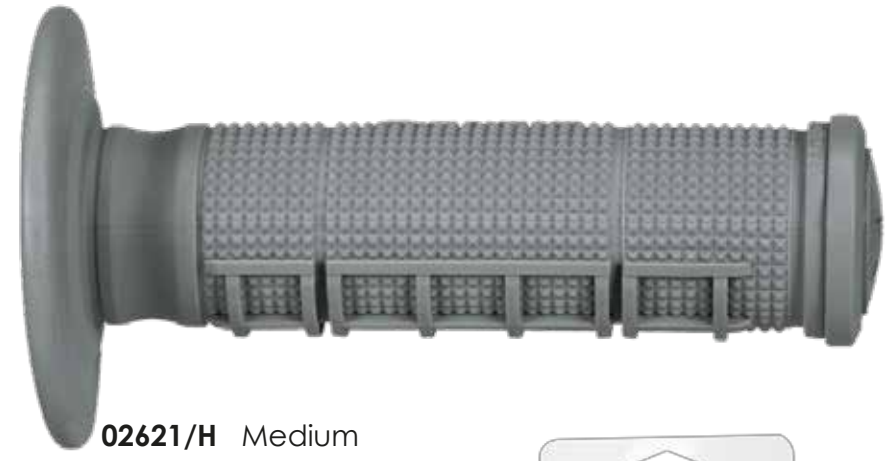

02621/H Medium



02621-N Soft

### Features

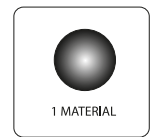

# GRIPS

# WAFLE

**GRIPS**

# MINI WAFLE HALSP



02621/A-G

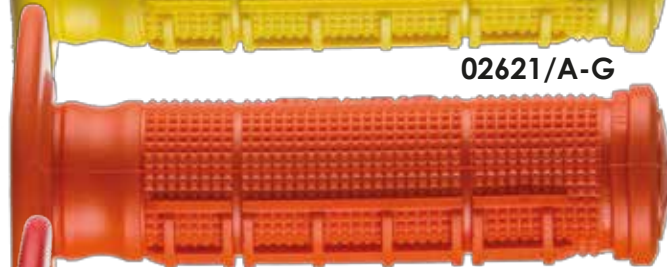

02621/A-AR

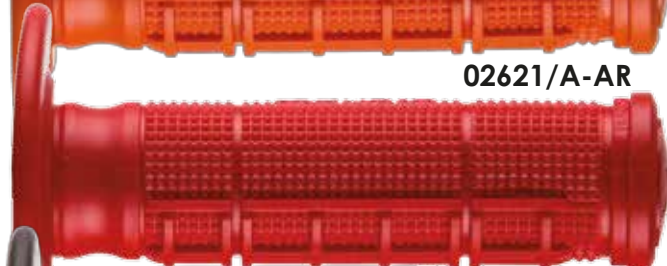

02621/A-R



02621/A-N



02621/A-GF

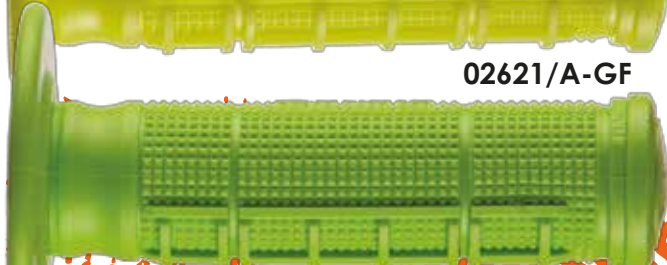

02621/A-L

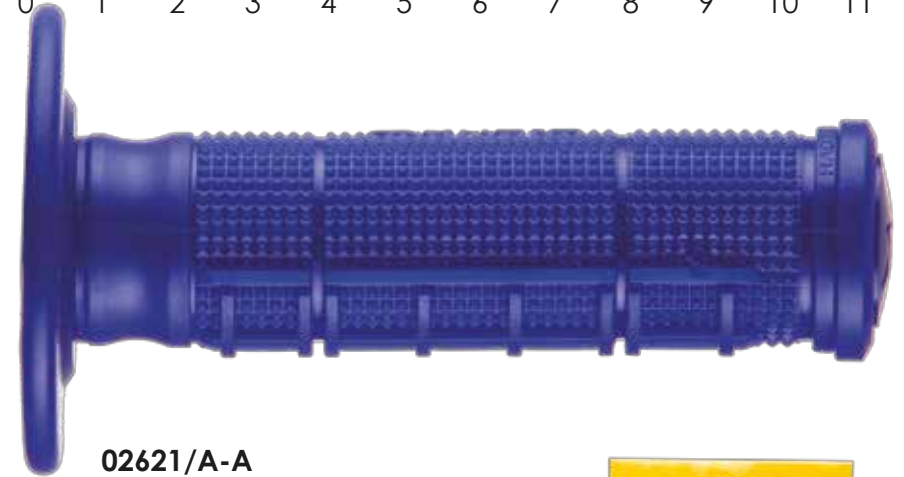
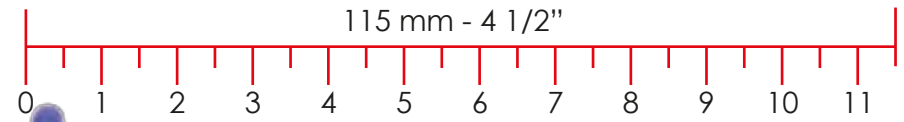

02621/A-A

### Features

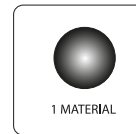

FLUO COLOR



115 mm - 4 1/2"



Front

01699 Soft

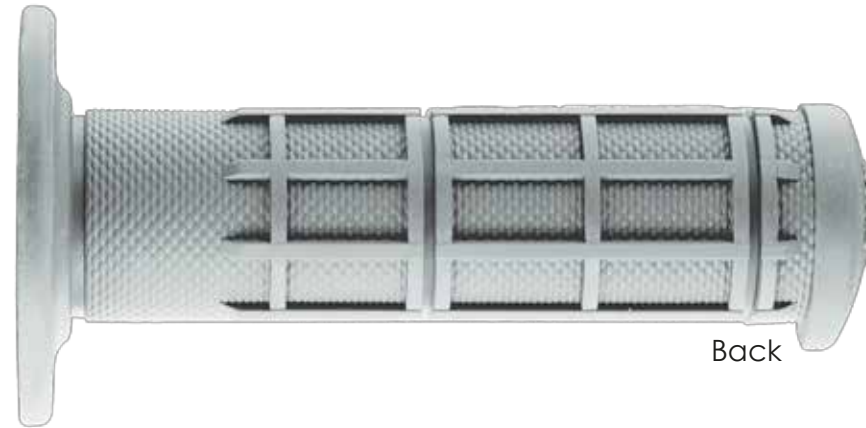

Back



01699/H Medium

### Features

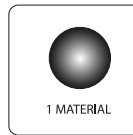
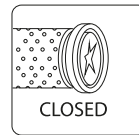

# GRIPS

# EXTREME

# 55

# GRIPS

ATV-CYCLE



02630-NGR

**Ø22-22**

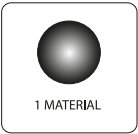

02620 A.S.P.

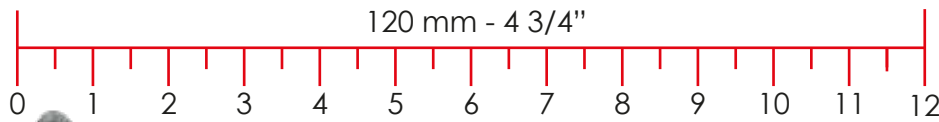
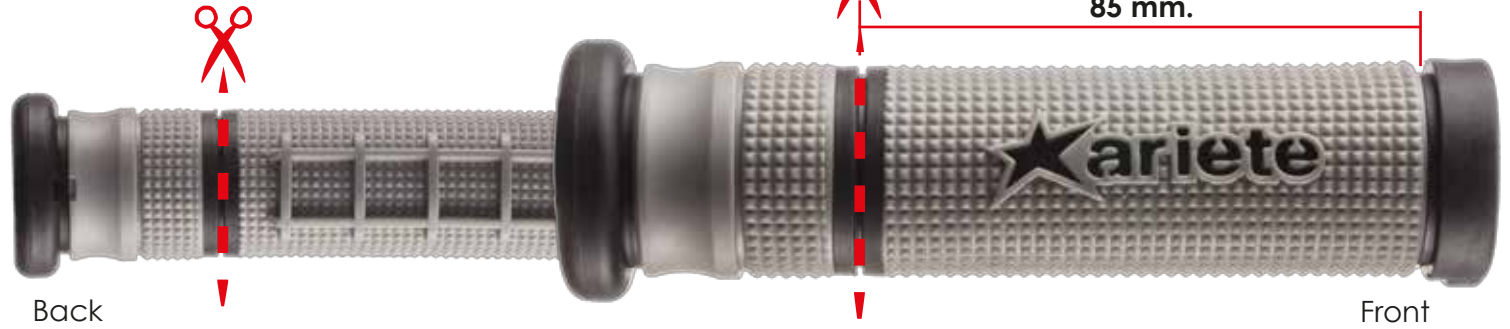
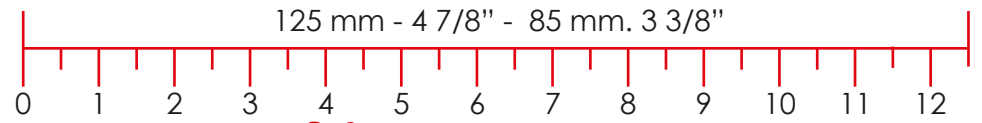

TRIAL

50

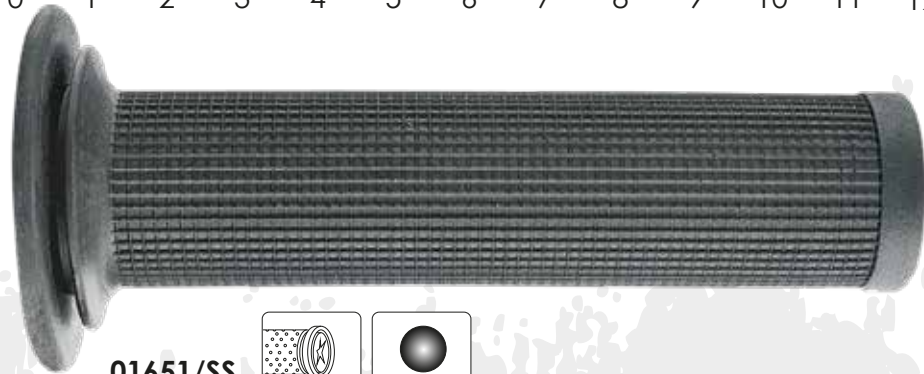

01651/SS



**120 mm**

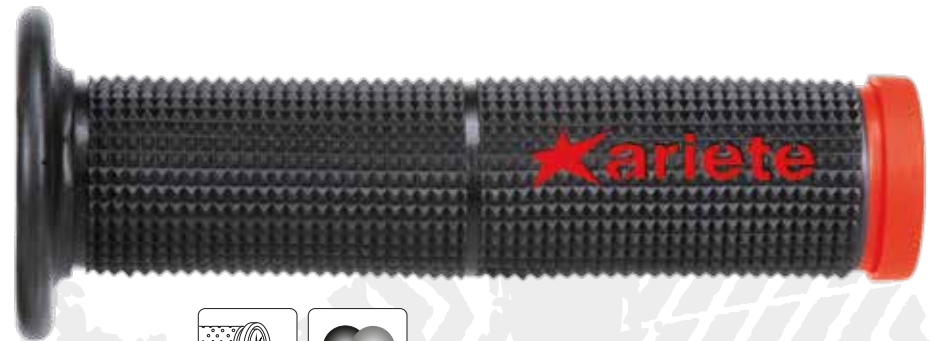

02617

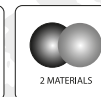
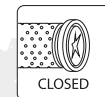

# RALLY

125 mm - 4 7/8"

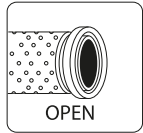
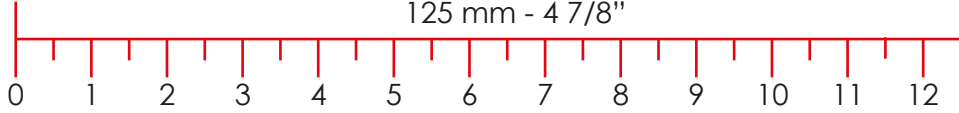

**02616**  
Tech. Foam +TP Caps

# CLASSIC MX

# GRIPS

120 mm - 4 3/4"

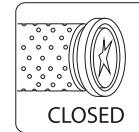
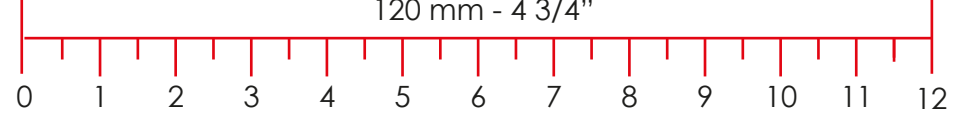

**01671**

# SNOWMOBILE

130 mm - 5 1/8"

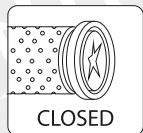
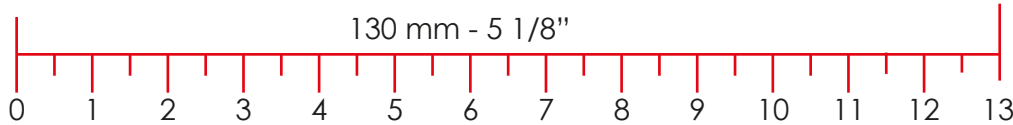

**02610-R**

**Ø22-22**



**02610-A**

# OFF ROAD ACCESSORIES

**BRAKE  
LOCK**



12951

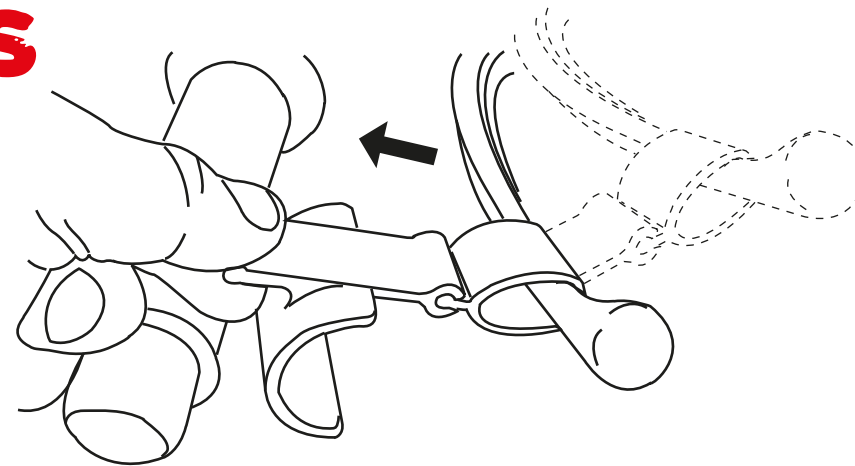

**MUD  
SCRAPER**



12952

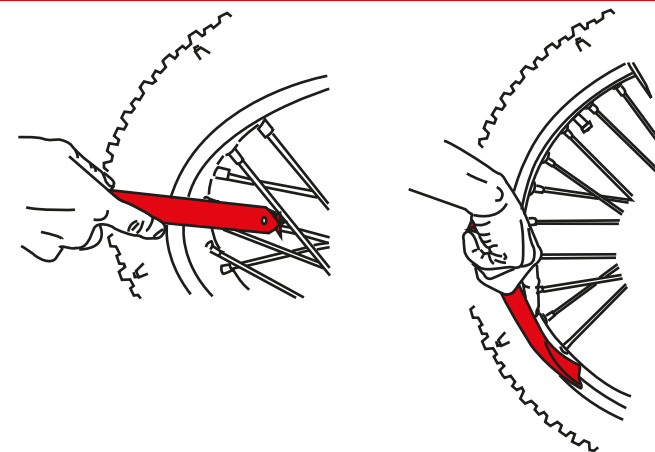

**SUPER FAST  
GRIP GLUE**

**60**



**20gr.**

12992



# OFF ROAD ACCESSORIES

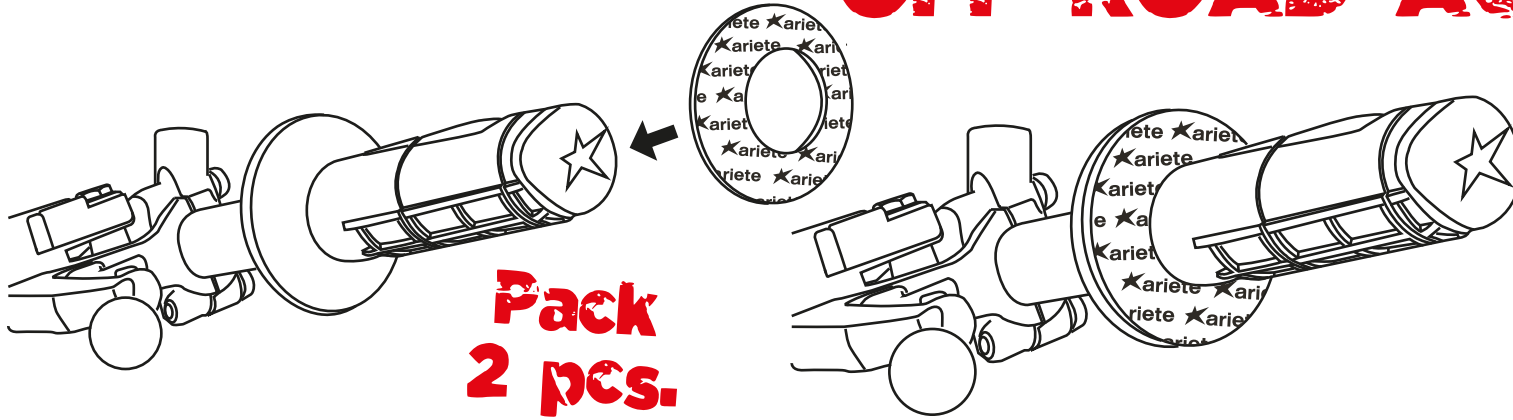

**Pack  
2 pcs.**



12929

**DONUTS**



11993



11993-R

**Pack  
10 pcs.**

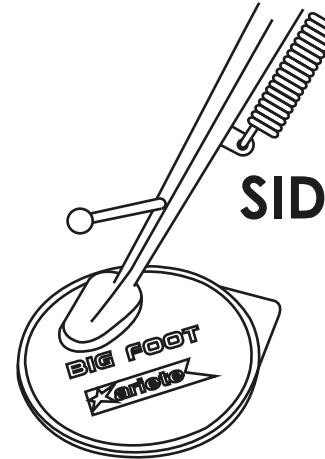

**SIDE STAND**

**BIG FOOT**

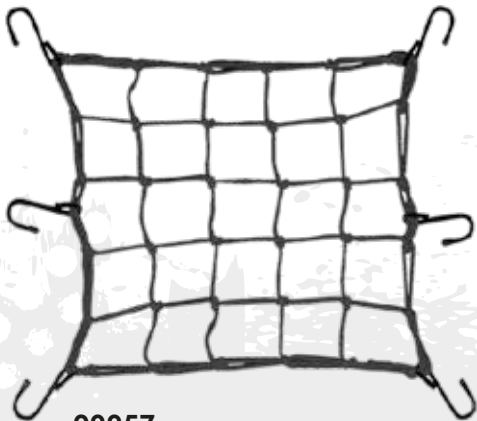

09957



10936

con valvola/ air-valve included/válvula incluida



10915 1,60"  
10916 1,85"  
10917 2,15"



10901  
Ø 19-38



13904  
Ø 24-48

**VARIOUS**

# OFF ROAD

# SPARK PLUG SCOVERS



**RACING**

- 5.000 Ohm resistance
- high performance ceramic resistor, suits  $\varnothing$  6,4 mm dia. SAE spark plug nut
- totally waterproof



12949/S  
silicone



12949  
EPDM

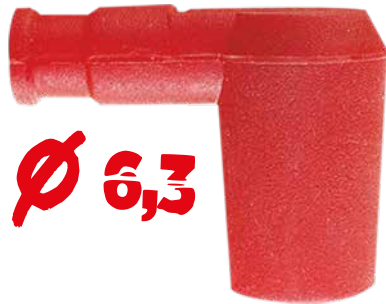

$\varnothing$  6,3

09965  
silicone



09965-A  
silicone



09965 /A  
silicone

**PACK  
5 PCS**

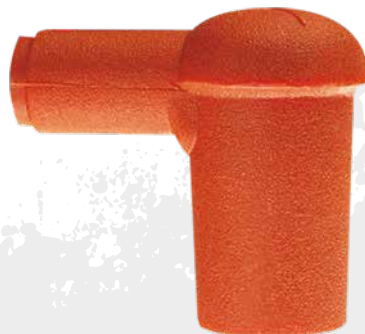

04999 small  $\varnothing$  3,9  
silicone

04999/A standard  $\varnothing$  6,3  
silicone

	Code	Colour	∅ Tube	∅ Slider	L. min	L. max
	<b>09932</b>	Black	40/43	57/60	75	500
	<b>09932-A</b>	Blue	40/43	57/60	75	500
	<b>09932-R</b>	Red	40/43	57/60	75	500
	<b>09941</b>	Black	28/32	52/54	55	310
	<b>09943</b>	Black	35/38	56/59	85	440
	<b>09950</b>	Black	43/46	58/63	90	600
	<b>06962</b>	Black	32/34	52/54	65	300
	<b>07901</b>	Black	35/38	56/60	85	440
	<b>07907</b>	Black	28/30	46/48	50	215
	<b>07995</b>	Black	38/41	58/62	95	430
	<b>07995-A</b>	Blue	38/41	58/62	95	430
	<b>07995-R</b>	Red	38/41	58/62	95	430
	<b>09974</b>	Black	43/45	57/60	70	240
	<b>09981</b>	Black	39/41	58/60	105	290
	<b>09942/A-A</b>	Blue	33/38	50/55	100	335

VINTAGE

ARTIST

HAND MADE  
GENUINE LEATHER



64



13990-NRF



13990-MCF

## Features

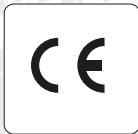
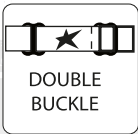

ROAD GRIPS

TECHNOLOGY

66



Daniilo Petrucci - Octo Pramac Yakhnich Team

# ROAD GRIPS

# TECHNOLOGY

built-in wire-on grooves with space to tighten the wire

built-in wire-on grooves with space to tighten the wire

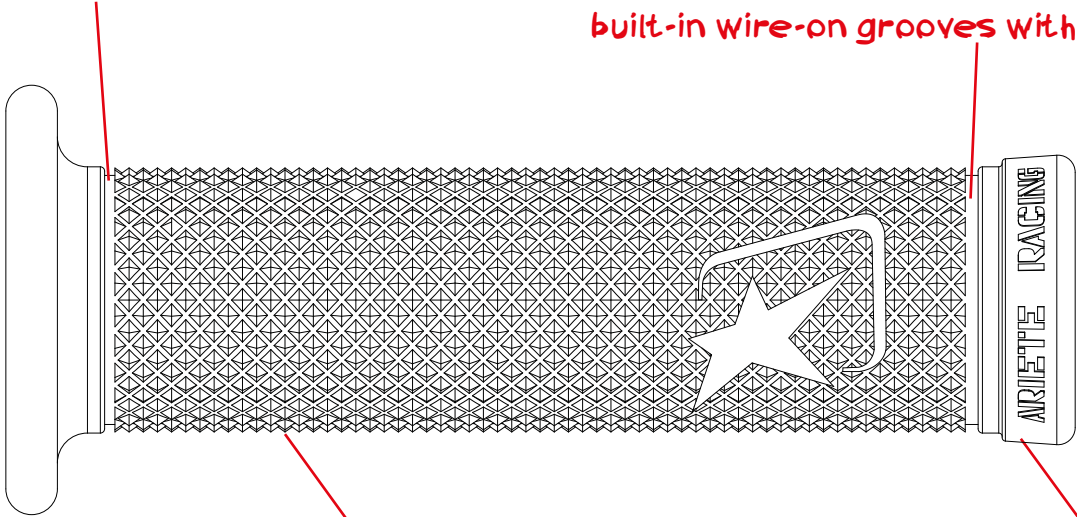

acute pyramid edges

outer flange for lateral grip

laser engineered mold

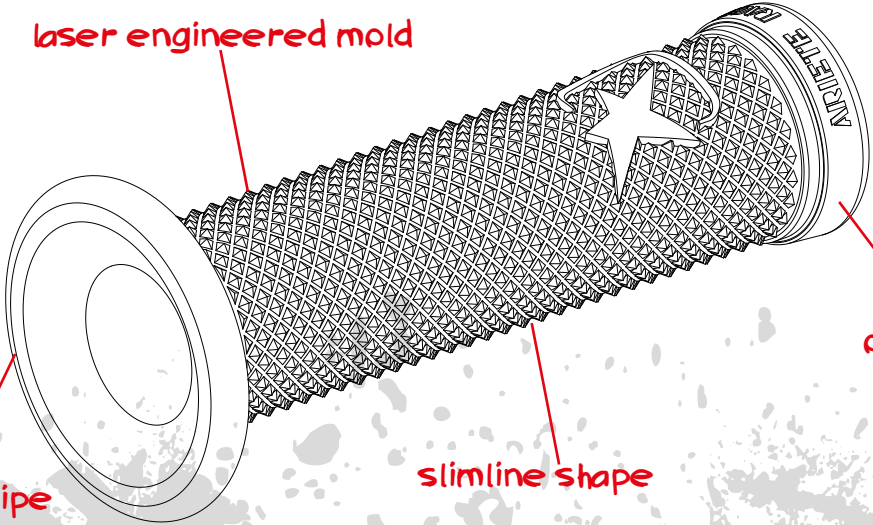

optimized for bar weights

optimized for throttle pipe

slimline shape

# ARIES GRIPS

125 mm - 4 7/8"

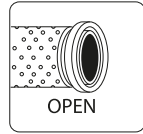

02636 Soft



CS

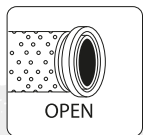
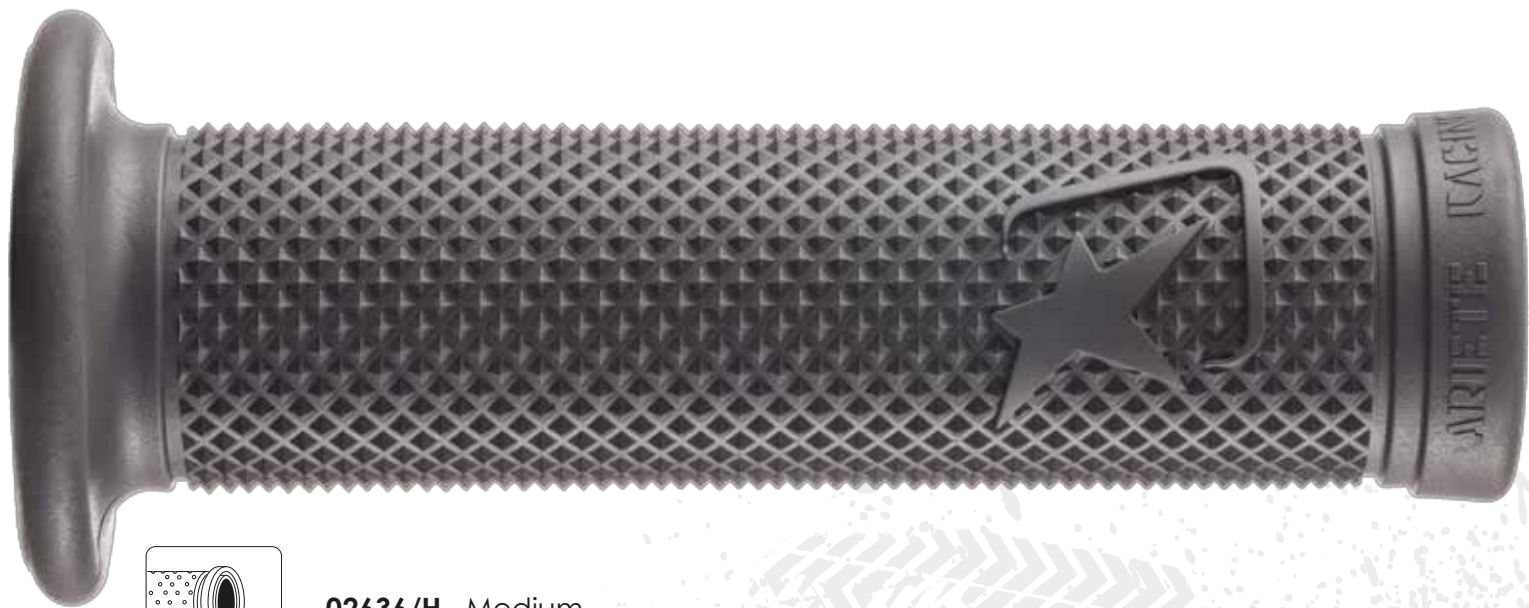

**02636/H** Medium

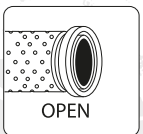

**02636-N** Soft



**02636/C-N** Soft



# GRIPS

# ALU RIB

# ALU RIB

# ALU RIB

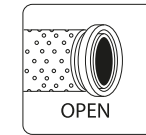
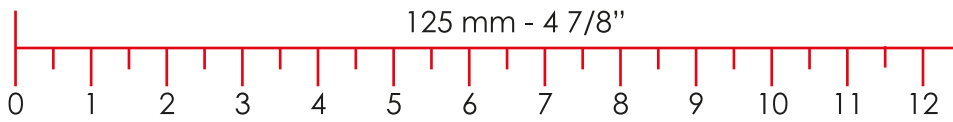

# LOCK ON GRIPS

- alluminio leggerissimo, ultra resistente
- manopola destra: compatibile con i comandi di serie
- manopola sinistra: fissaggio di sicurezza con viti
- chiave a brugola compresa

- superlight and extra resistant aluminium
- right grip: suitable for standard twist grips
- left grip: screw fastening
- allen key provided

- aluminio ligero y ultra-resistente
- puño derecho: compatible con el acelerador de serie
- puño izquierdo: compatible con los tornillos de seguridad
- llave allen incluida

## UNIVERSAL FITTING





02631-N



02633-N



02631-ALL



02633-ALL



02631-GO



02633-GO

**SPARE PARTS**

**Pack 2 pcs.**



12999



13905



12998

# ALU RUB

WEIGHTS

- massa in alluminio anodizzato ricavato dal pieno
- viti in acciaio Inox antiruggine
- 2 parti in gomma vulcanizzata all'interno del manubrio

- masa en aluminio anodizado sacada de la parte llena
- tornillos en acero inoxidable anti óxido
- 2 partes de goma vulcanizada en el interior del manillar

- anodised body machined from billet alloy
- stainless steel screws
- 2 vulcanised rubber spacers to grip the i.d. of the bar



BAR

72



**GRIPS**

**ESTORIL**

**120 mm**

120 mm - 4 3/4"

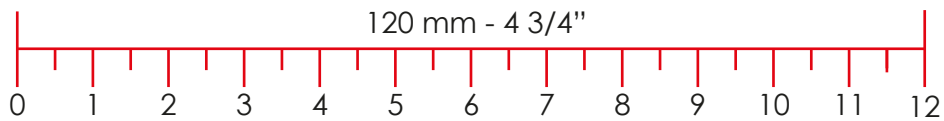

02615-R

Front

Back



02615-SBK

02615-A

**Superbike Gel**

**Features**

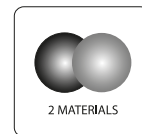
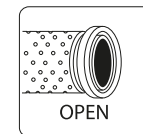

**32**

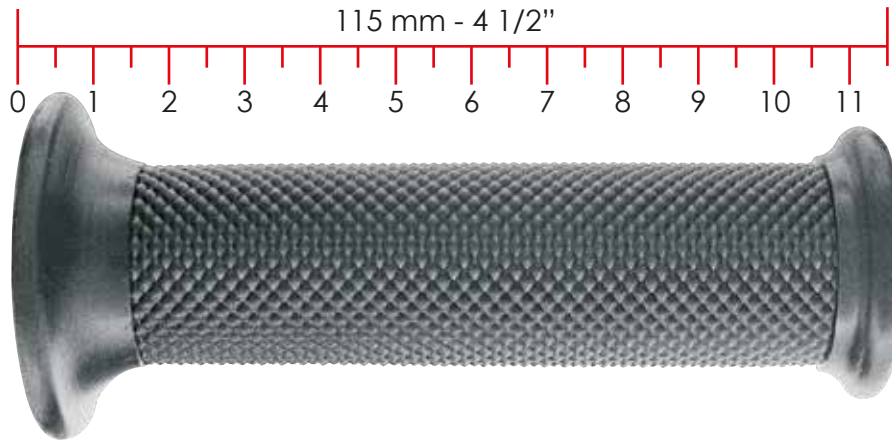

**115 mm**

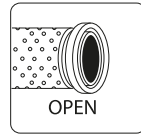

**01663/SSF Super Soft**



**GRIPS**

**120 mm**

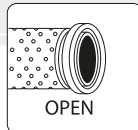
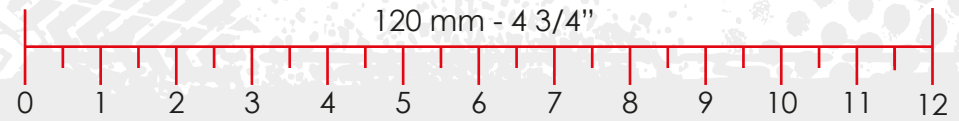

**02635/SSF Super Soft**

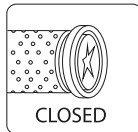

**02635/SS Super Soft**



**STANDARD**

# GRIPS

# 120 mm

# STANDARD

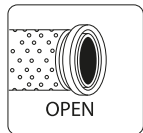

**02623/SSF** Super Soft

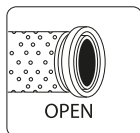
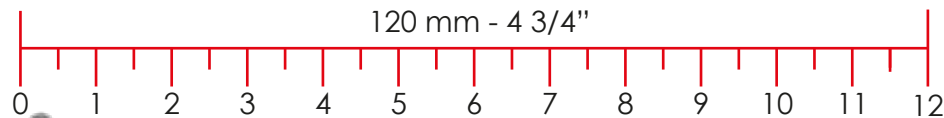

**02625/SSF** Super Soft

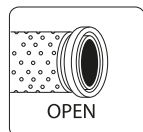

**02626/SSF** Super Soft  
**02626/A/F** A.S.P.

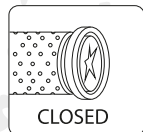

**02626/SS** Super Soft  
**02626/A** A.S.P.



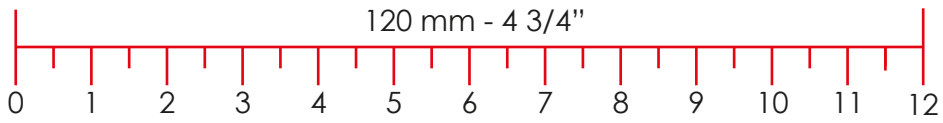

**120 mm**

**GRIPS**

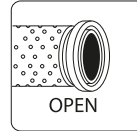

**01661/SSF** Super Soft

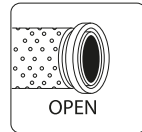

**01686/SSF** Super Soft

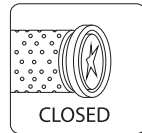

**01686/SS** Super Soft

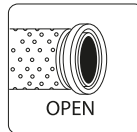

**01681/SSF** Super Soft  
**01681/A** A.S.P.



**STANDARD**



**GRIPS**

**STANDARD**

**120 mm**

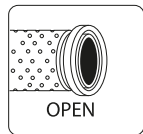
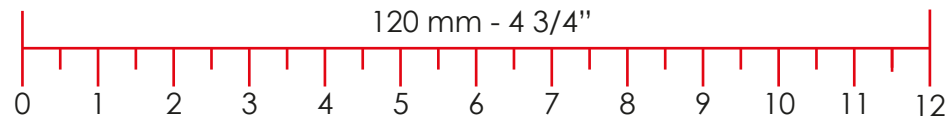

**01685/SSF** Super Soft

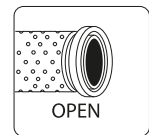

**01680/SSF** Super Soft

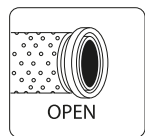

**01694/SSF** Super Soft

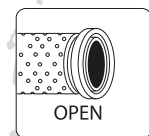

**01679/SSF** Super Soft



**30**

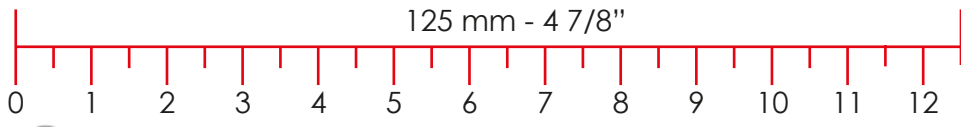

**125 mm**

**GRIPS**

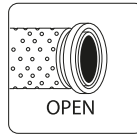

**02636-N** Soft

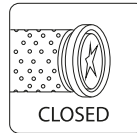

**02636/C-N** Soft

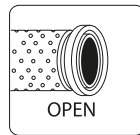

**02636/H** Medium

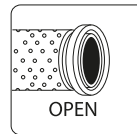

**02636** Soft

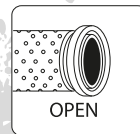

**01682/SSF** Super Soft



# GRIPS

# STANDARD

**125 mm**

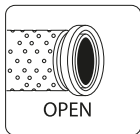
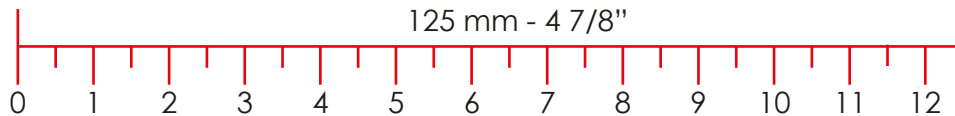

**01616** Foam Plus + TP Caps

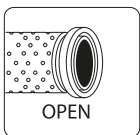

**01690/F** Super Soft

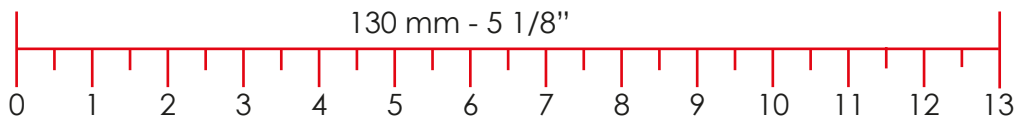

**130 mm**

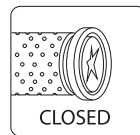
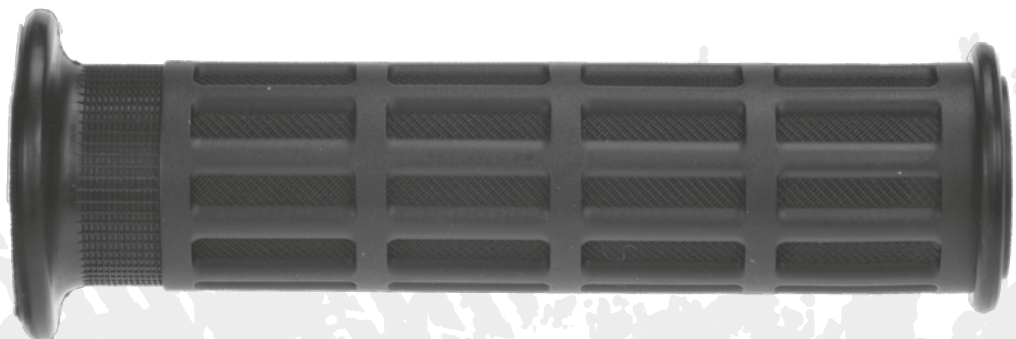

**01612** Rubber  
**01612/SS** Super Soft

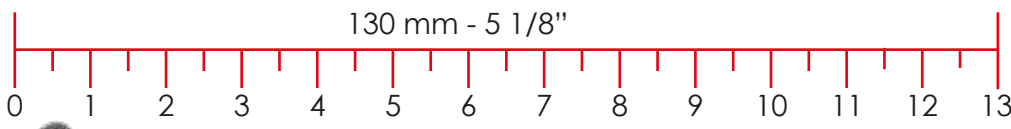

**130 mm**

**GRIPS**

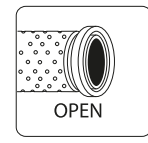

**02613-N** Soft

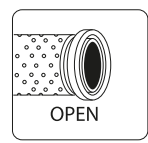

**02613/H** Medium

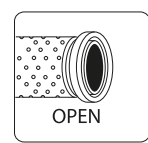

**02613** Soft

**STANDARD**

**C1**

# GRIPS

# SUITABLE FOR BMW

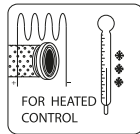
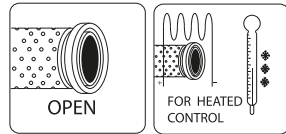

**02624/L**  
Ø26-26

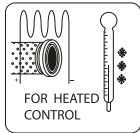
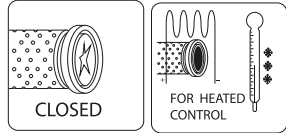

**02624/C**  
Ø26-26

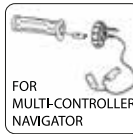
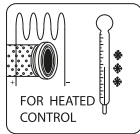
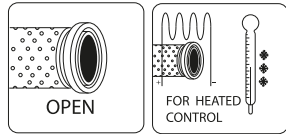

**02624/LN**  
Ø26-26



**01690/F**  
Ø22-26

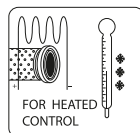
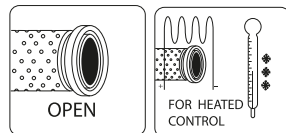

**01690/F/24**  
Ø26-26

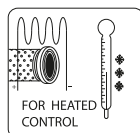
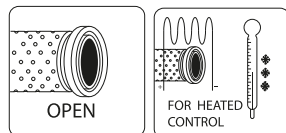

**01690/F/24N**  
Ø26-26

**125 mm**  
**Super Soft**

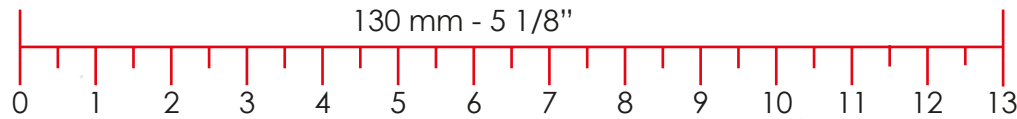
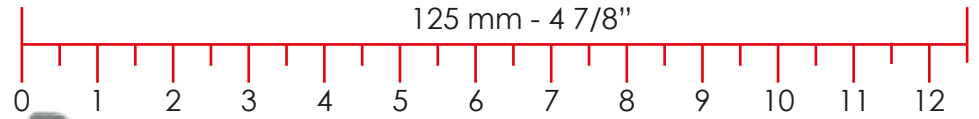

**130 mm**

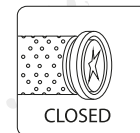

**02634**  
Ø22-26 Rubber



# TELELEVER BMW BOXER

BMW CC. : 850, 1100, 1150, 1200

BMW SERIES: R, RS, RT, S, GS, GS ADVENTURE



13911

cuffia snodo / ball joint boot / fuelle rotula dirección

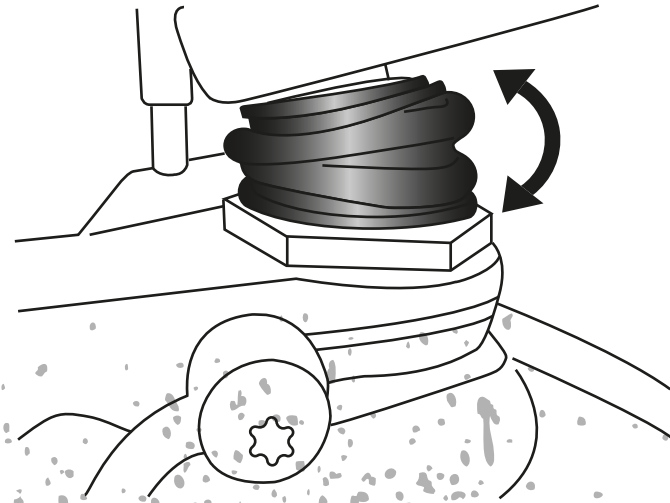

# BRAKE CALIPERS SEAL KIT

BMW SERIES: R65 (85-95), R80 (81-95), R100 (77-84),

R1100 (92-200 I), K75 (85-95), K100 (83-92), K1100 (92-96)



**EPDM HP**  
Special Compound

13855-PI

Guarnizioni pinza freno / Brake calipers Seal kit / Juntas de pinzas de freno

**EPDM HP**  
Special Compound

Tutti i componenti in gomma di questo kit, prodotti in Italia dalla Ariete, sono rettificati e testati singolarmente per garantire la perfezione della tenuta negli impianti frenanti.

**ATTENZIONE**  
Solo per liquido freni DOT 3 o DOT 4

The rubber brake seals in this kit are made in Italy by Ariete. After final grinding of the working surfaces, they are individually tested to guarantee their efficiency once fitted to the user's vehicle.

**WARNING**  
Use only DOT3 or DOT4 brake fluid

SUITABLE FOR BMW



# GRIPS

# SUITABLE FOR HONDA FOR

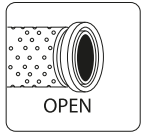
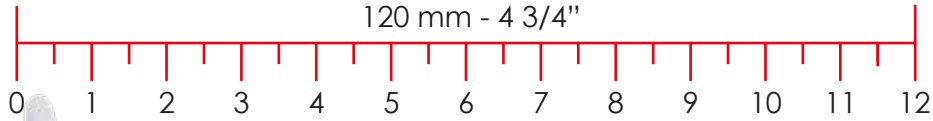

**01687-C2R** T.S.C

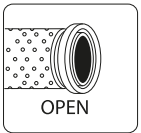

**01661/SSF** Super Soft

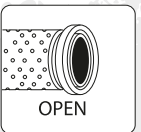

**01686/SSF**  
Super Soft

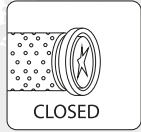

**01686/SS**  
Super Soft

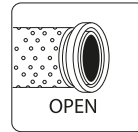
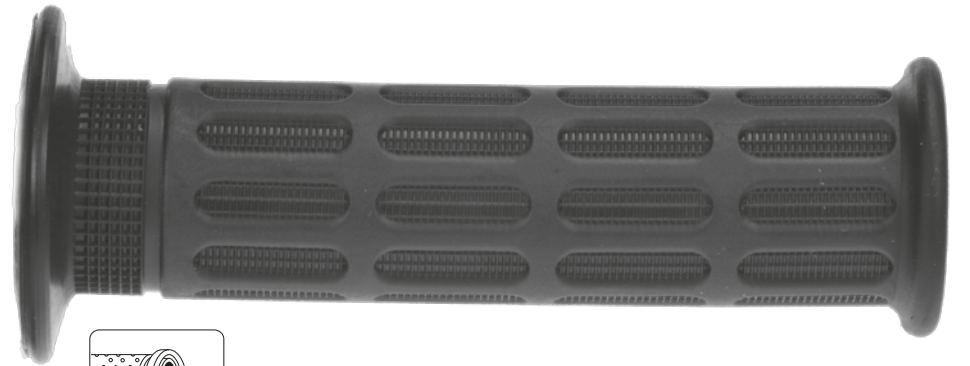
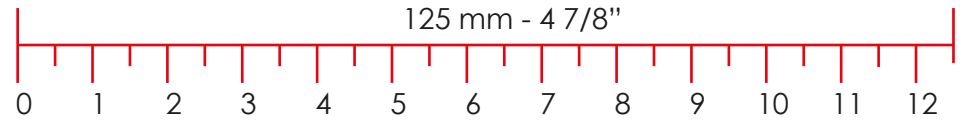

**01682/SSF** Super Soft

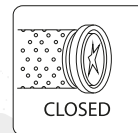
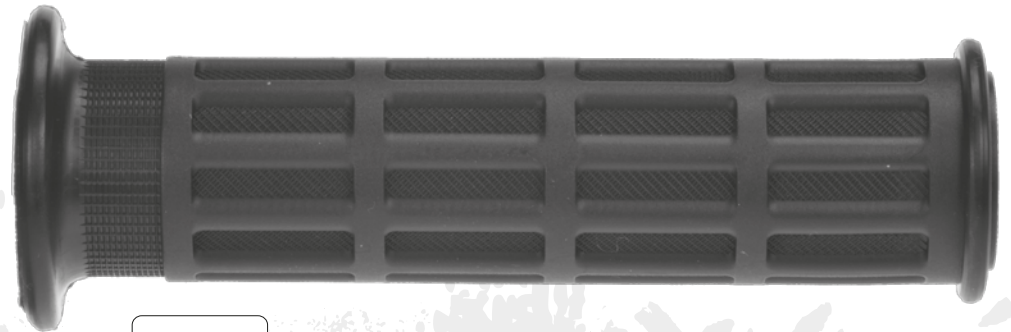
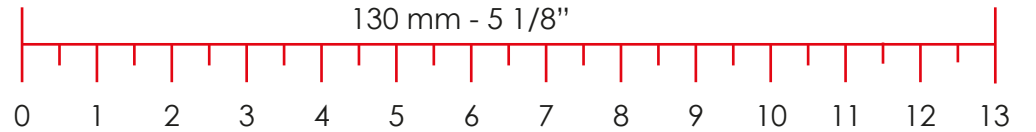

**01612** Rubber  
**01612/SS** Super Soft

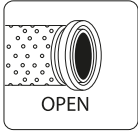
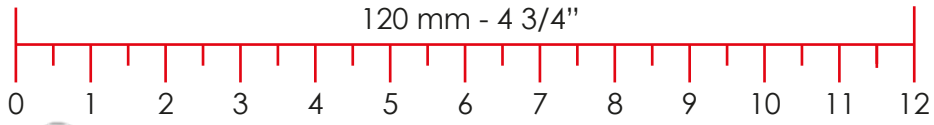

**01685/SSF** Super Soft

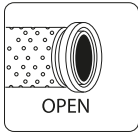

**01679/SSF** Super Soft

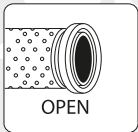

**02625/SSF** Super Soft

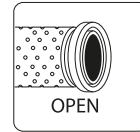

**01687-NJ** T.S.C

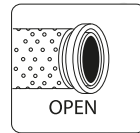
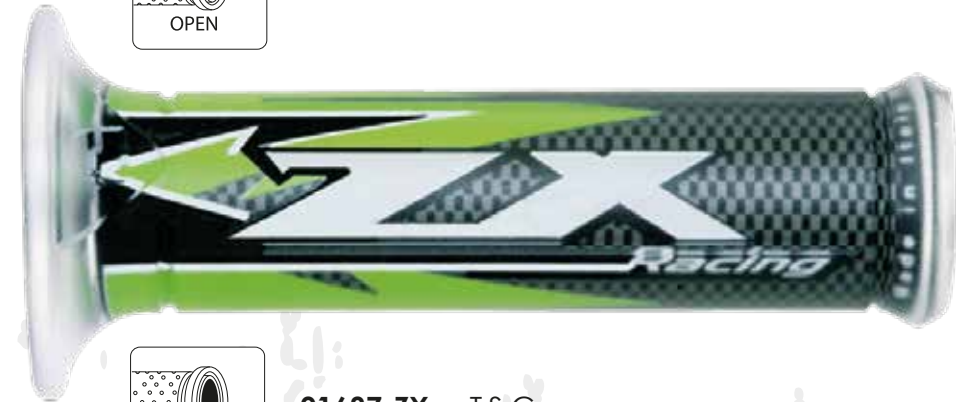

**01687-ZX** T.S.C

**GRIPS**

**SUITABLE FOR KAWASAKI**



**GRIPS**

**SUITABLE FOR SUZUKI**

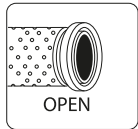
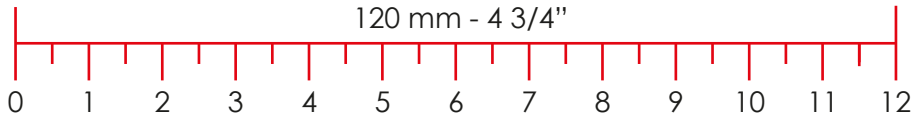

**02623/SSF** Super Soft

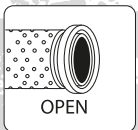
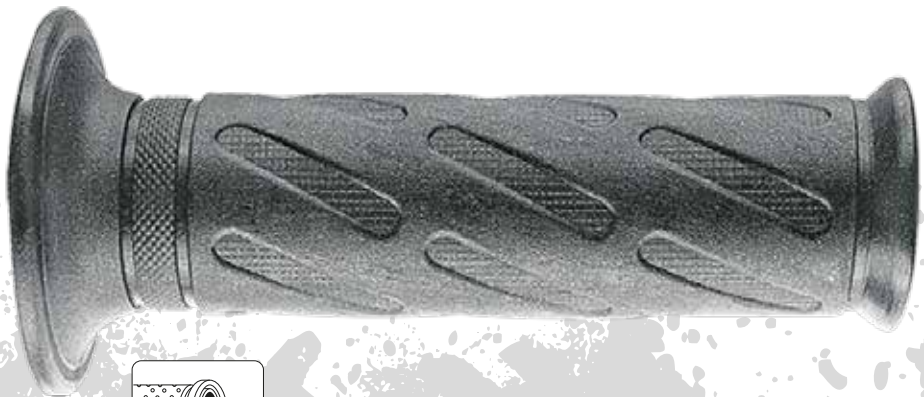

**01680/SSF** Super Soft

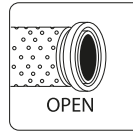
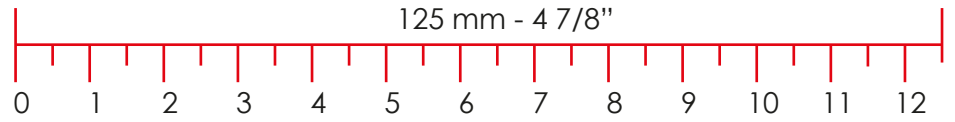

**01687-GSRA** T.S.C

**GRIPS**

**SUITABLE FOR YAMAHA**

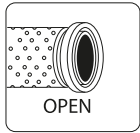
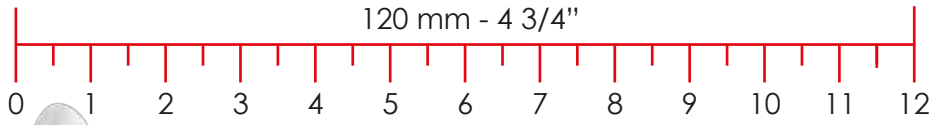

**01687-R1** T.S.C

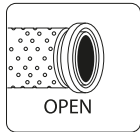

**01681/SSF** Super Soft  
**01681/A** A.S.P.

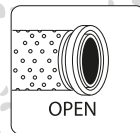
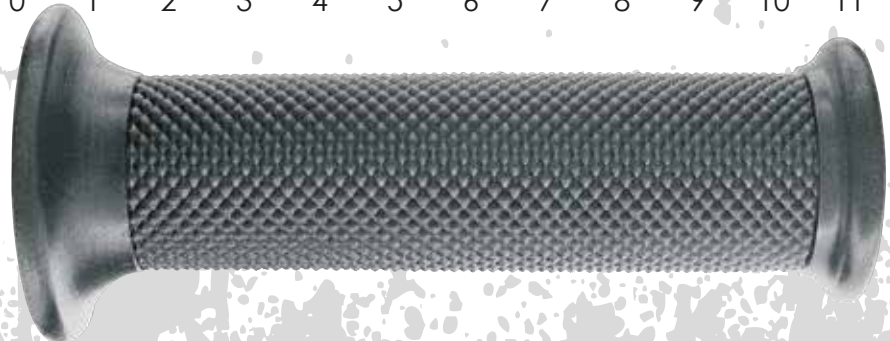
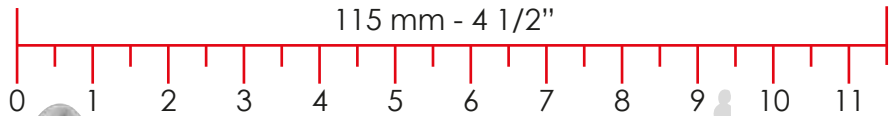

**01663/SSF** Super Soft

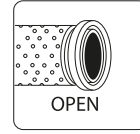

**01694/SSF** Super Soft

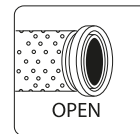

**02626/SSF** Super Soft  
**02626/A/F** A.S.P.

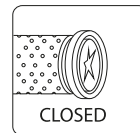

**02626/SS** Super Soft  
**02626/A** A.S.P.



# GRIPS

SUITABLE FOR PIACCIO  
FOR

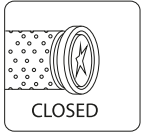
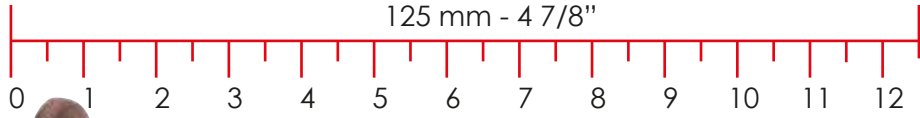

**01683-M** A.S.P.

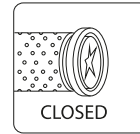
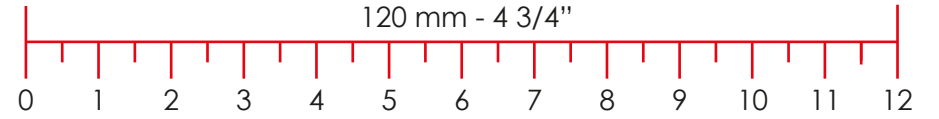

**01678** A.S.P.

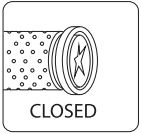

**01683** A.S.P.

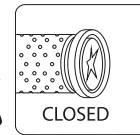
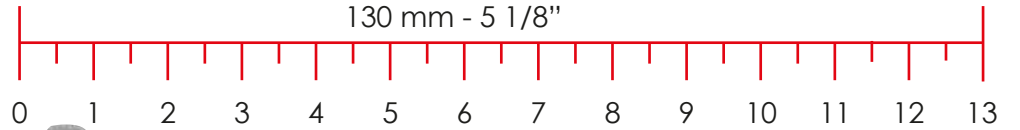

**01626/V** A.S.P. Vespa  
Ø22-22 - 7/8"



**01609/V** A.S.P. Vespa  
Ø22-22 - 7/8"

# VESPA



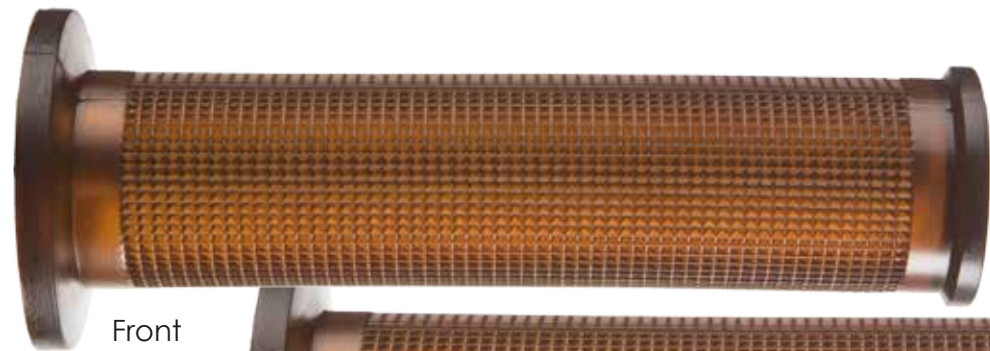
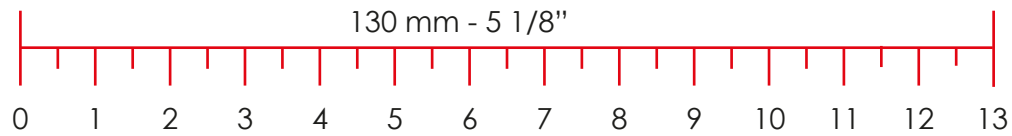

Front

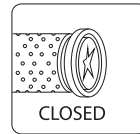

01617/A-P Rubber

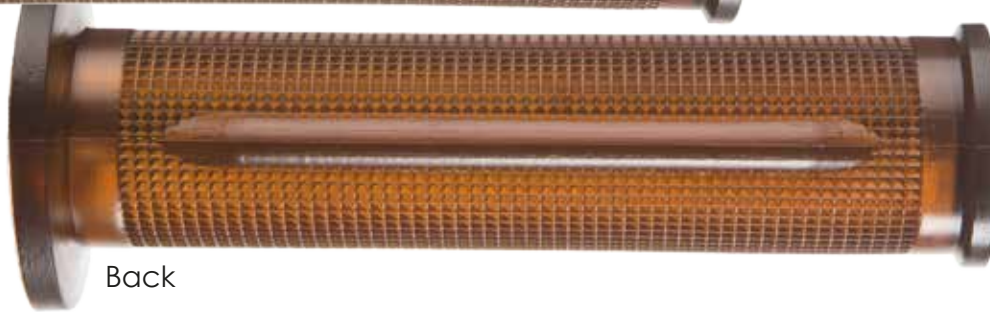

Back

**130 mm**

**GRIPS**  
**VINTAGE**  
**STYLE**

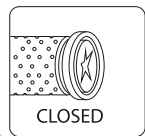

01617/A

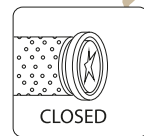

01617/A-R



# GRIPS

# VITALITY



FLUO COLOR



02635/AFGF



02635/A-GF

FLUO COLOR



02635/AFOF



02635/A-OF

FLUO COLOR



02635/AFVF



02635/A-VF

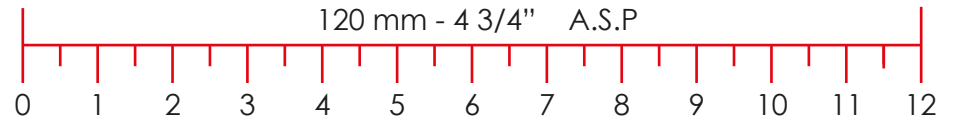

02635/A/FR



02635/A-R



02635/AFAS



02635/A-AS



02635/A/FN



02635/A-N

# GRIPS

# SCOOTER

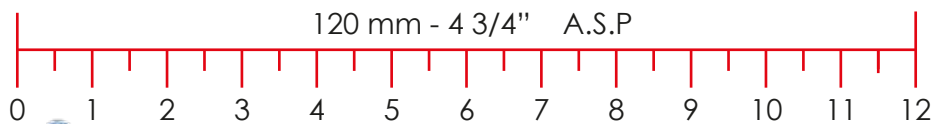

01670-A A.S.P.

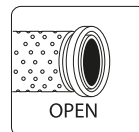
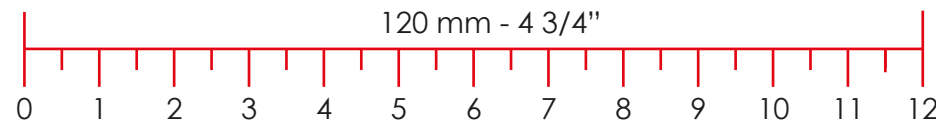

02632/A/F A.S.P.

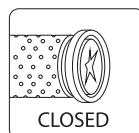

02632/A A.S.P.



01670 A.S.P.



01668/A A.S.P.

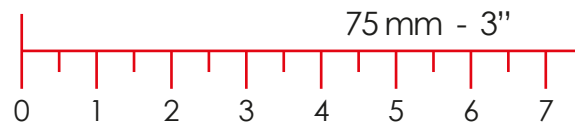

11944 A.S.P.



**Pack  
2 pcs.**

**GRIPS**

**HARRIS'S ROAD**  
**92**

**Harris's**<sup>®</sup>

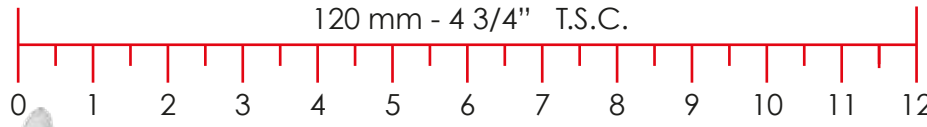

**120 mm**

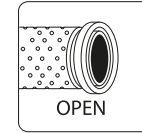

**01687-HRR** T.S.C.

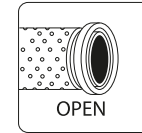

**01687-HRGR** T.S.C.

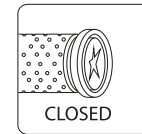

**01687-NC** T.S.C.

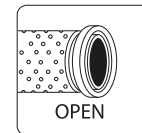

**01687/F-NC** T.S.C.

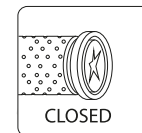

**01687** T.S.C.

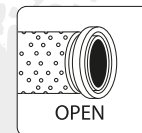

**01687/F** T.S.C.  
**01687/LF** T.S.C.

**125 mm**

**Harris®**

**ACCESSORIES**



**12970-R**



**12970-T**

Trasparente - Transparent



**12970-TR**

Trasparente - carbonio  
Transparent - carbon look



**12970**

## TANK PROTECTORS PUZZLE

- resinatura trasparente resistente ai raggi UV
- materiale antigraffio e durevole
- adesivo di alta qualità  
(non danneggia la vernice del serbatoio)

- perfectly UV-resistant transparent resin
- anti-scratch and long-lasting material
- top quality adhesive  
(no damage to fuel tank)

- resina trasparente resistente a los rayos UV
- material anti-rayas y resiste el paso del tiempo
- material adhesivo de altísima calidad  
(no daña la pintura del depósito)

**HARRIS ROAD**

**ROAD**

**94 ACCESSORIES**



# RACING VALVES FOR TUBELESS

- valvola di sicurezza in alluminio per pneumatici tubeless
- l'angolazione a 90° permette l'accesso durante il gonfiaggio
- mantiene la pressione del pneumatico
- conf. 2 pezzi

- safety valve in aluminium for tubeless wheels
- practical access for inflation
- no loss of pressure in the tyre
- sold in pairs

- válvula de seguridad en aluminio para neumáticos sin cámara
- la inclinación de la válvula a 90° permite un practico acceso para el hinchado
- mantiene la presión del neumático
- se venden por pares

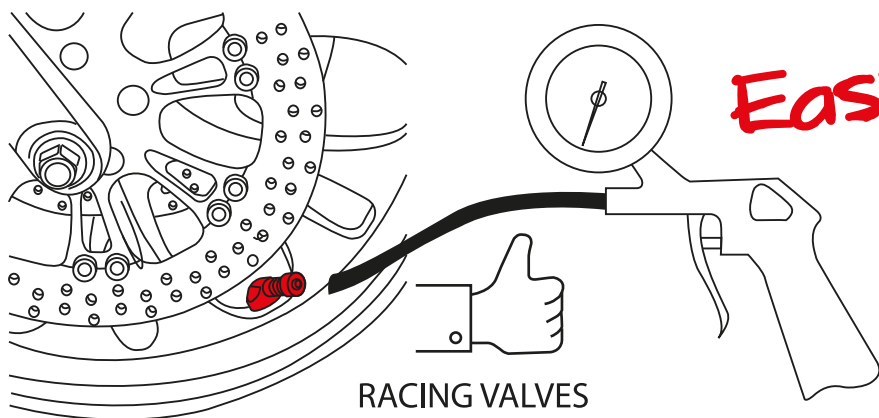

**Easy + Safe**

**TUV TA - MAN - 9032/07**

cod.11978 = Ø 11,3 STANDARD RIMS

cod.11971 = Ø 8,3 SPECIAL RIMS Antera, Brembo, Marchesini, Marvic, OZ Racing



**11970 - GOLD**  
Ø 11,3

**11970-R**  
Ø 11,3

**11970**  
Ø 11,3

**11971-N** Ø 8,3  
**11970-N** Ø 11,3

**11970 - ALL** Ø 11,3  
**11971 - ALL** Ø 8,3

**ROAD**  
**ACCESSORIES**

**ACCESSORIES**

**TECHNICAL**



**ARI**®

THE ORIGINAL  
**FORK OIL SEALS**

**ariete**®

# AVOID ARI SEAL FAKES 7 STEPS TO IDENTIFY AN ORIGINAL ARI BY ARIETE ACCESSORIES

NEW PACK DESIGN

19MM PACK HEIGHT



ARI BAR CODE ON ALL ARI PACKS



ARISIL GREASE INCLUDED

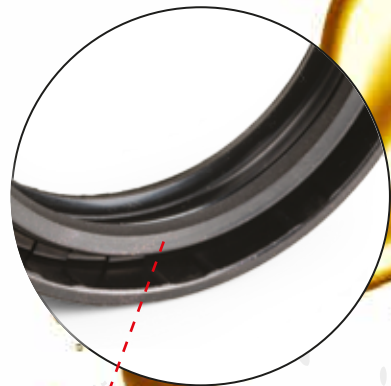

FINE-GROUND MATT INNER LIP  
NO FLASH

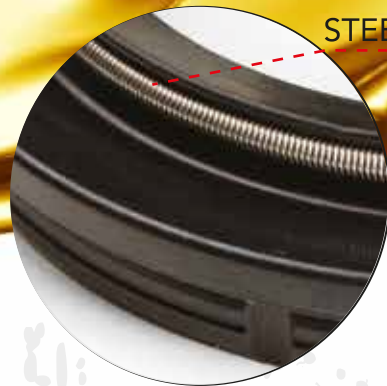

STEEL SPRING



ARIETE NAME ON EVERY SEAL



# TECHNICAL

# 97

# ACCESSORIES **ARI THE ORIGINAL FORK OIL SEALS BY ARIETE**

TECHNICAL

L'anello di tenuta paraolio di **Ariete** è il top esistente nel mercato per l'alta qualità dei materiali utilizzati e l'elevatissimo grado di finitura. La linea **ARI** con oltre 160 tipi diversi equipaggia più di 35.000 modelli di moto con forcelle tradizionali e rovesciate (USD) dal funzionamento teleidraulico degli anni 60 a quello pneumatico (Aria) sempre più attuale nel mondo Off-Road. **ARI**, il paraolio di Ariete sinonimo di perfezione assoluta.

*Ariete fork oil-seals are the best you can get. This claim is justified by the quality of the materials used, and attention to detail in their design and manufacture. The **ARI** range has more than 160 different seal sizes. These cover more than 35,000 different motorcycle models with both traditional and upside-down forks. We have seals for classic 1960s telescopic forks extending through to the air forks now common both on- and off-road. **ARI** fork oil-seals - perfection, from Ariete.*

*El retén de horquilla **Ariete** representa el máximo nivel alcanzado en el mercado existente gracias a la alta calidad de los materiales utilizados y también al alto grado de acabado. La línea **ARI**, con más de 160 tipos diferentes equipa a más de 35.000 modelos de motocicletas con horquillas convencionales y telescópicas invertidas (USD), desde aquellas de funcionamiento hidráulico de los años '60 hasta las de funcionamiento neumático (Aire) cada vez más presentes en el mundo Off-Road. **ARI**, el retén de Ariete sinónimo de perfección absoluta.*



## ARIETE FORK OIL SEALS, gli specifici anelli di tenuta per forcelle

L'anello di tenuta paraolio per forcella prodotto dalla Ariete si differenzia da tutti gli altri disponibili sul mercato per l'alta qualità ed unicità del materiale utilizzato per la sua realizzazione: l'elastomero carbossilico XNBR.

Questa miscela infatti possiede caratteristiche eccezionali di resistenza alla abrasione, alla temperatura ed agli olii con particolari additivi usati nelle moderne forcelle per moto e scooters. L'anello di tenuta per forcella lavorando in senso longitudinale sullo stelo è sottoposto ad una notevole azione abrasiva che unita al calore generato dallo scorrimento provoca un processo di deterioramento della parte in gomma che già è messa a dura prova dall'aggressione chimica degli olii con relativi additivi. La normale gomma nitrilica NBR, solitamente impiegata da tutti i produttori di anelli paraolio, è una scelta mediocre determinata da fattori di economicità.

Lo Staff Tecnico della Ariete, dopo approfonditi studi e sperimentazioni e supportato dall'esperienza maturata dall'Azienda in sessanta anni di attività, ha adottato per questa linea di anelli paraolio l'elastomero carbossilico XNBR che rispetto al tipo normale NBR presenta le seguenti performances:

Le sofisticate tecnologie di produzione impiegate dall'Ariete permettono di ottenere prezzi altamente competitivi nonostante il costo dell'elastomero XNBR sia quasi il doppio del tipo normale permettendo al Cliente Ariete di avere un prodotto di altissima qualità che soddisfi le più esigenti aspettative ad un prezzo equo.

## ARIETE FORK OIL SEALS, custom-made for your fork

*Ariete fork oil seals are different! The quality of their execution is matched by the unique nature of the material used: the carboxylated elastomer known as XNBR.*

*This compound offers unique characteristics of resistance to abrasion, to high temperatures, and to the complex lubricants with numerous additives, which are used in modern forks as fitted to motorcycles and scooters.*

*The reciprocating action of the fork tube against the seal subjects it to a notable degree of abrasion, which is complicated by the heat generated as a result of hydraulic displacement within the fork, plus the friction of the components involved. This mechanical wear and tear leads to accelerated ageing of the rubber which is also obliged to deal with the chemical action of the various additives in the lubricant. Oil seals are normally made from a nitrile rubber, known as NBR. This is used because it is cheap, and plentiful, not because NBR is the best material for the job. Our technical staff have accumulated 60 years of experience in the rubber industry, and have spent many years looking for a better material for the manufacture of oil seals. In our view, the carboxylated elastomer known as XNBR has the following major advantages when compared with NBR:*

*Although the cost of XNBR is almost twice that of NBR, the sophisticated technology used to make our oil seals enables us to put them on the market at highly competitive prices. In this way, the Ariete Customer enjoys the benefits of a very high quality product, which satisfies the most demanding requirements, at a competitive price.*

## ARIETE FORK OIL SEALS, el retén específico para horquilla

*El retén de horquilla producido por Ariete se diferencia de otros productos existentes por la alta calidad y unicidad del material utilizado para su fabricación: el elastómero carbossilico XNBR.*

*Esta mezcla posee en efecto características excepcionales de resistencia a la abrasión, a la temperatura y a los aceites que con aditivos muy específicos se utilizan en las horquillas de motocicleta y scooter. El retén para horquilla, al trabajar en sentido longitudinal a la barra está expuesto a una notable acción abrasiva que unida al calor provocado por la fricción generan un proceso de deterioro de la goma. Es importante entender que esta ya ha sido puesta a una dura prueba debido a la agresión de los aditivos que tiene los aceite para horquilla. Los compuestos de gomas nitrilicas NBR, normalmente empleadas en la producción de todos los retenes de horquilla es una mediocre elección determinada por factores exclusivamente económicos. Sesenta años de experiencia, sobre todo en el exigente mundo industrial, han determinado que el equipo dirigente de Ariete determinara que la producción de estos productos ha de tener de forma exclusiva el elastómero de carbonosilicio XNBR que respecto a los tipos normales NBR tiene las siguientes ventajas:*

*Las sofisticadas técnicas de producción empleadas en Ariete permiten obtener unos precios altamente competitivos a pesar de que el costo del compuesto XNBR es prácticamente el doble del tipo normal. Para nosotros es importante explicar que el Cliente Ariete obtiene unos productos de altísima calidad que satisfarán las mas exigentes expectativas.*

TEST	STANDARD	NBR NORMAL	XNBR
Load to breaking point (PSI)	ASTM D412	2130	3270
NBS abrasion resistance %	ASTM D1630	210	590

# ACCESSORIES

# ARISIL

TECHNICAL

## ARISIL lo speciale grasso lubrificante per anelli di tenuta

L'anello di tenuta paraolio per forcella **ARI** è prodotto con una miscela di gomma specifica per resistere agli olii, con relativi additivi, utilizzati nelle sospensioni. Questa miscela è completamente diversa da quella usata normalmente per gli anelli paraolio per alberi rotanti, in quanto deve resistere in modo diverso all'aggressione chimica causata dagli olii ed al lavoro meccanico in senso longitudinale tipico della forcella. I nostri anelli di tenuta paraolio **ARI** sono inoltre concepiti con una struttura di labbri di tenuta particolari con diverse sezioni per meglio resistere e al tempo stesso ridurre il più possibile l'attrito dello stelo all'interno del paraolio.

Nel corso degli anni si è evidenziato il ruolo indispensabile di un lubrificante separatore tra lo stelo e l'anello in gomma che riduca il più possibile l'attrito senza compromettere la tenuta della guarnizione. Per risolvere questo problema abbiamo testato diversi grassi e la scelta è caduta su uno speciale grasso silconico, prodotto negli USA studiato appositamente per le applicazioni gomma-metallo degli organi meccanici dei veicoli spaziali della NASA. Il vantaggio di questo grasso particolare che abbiamo denominato **ARISIL** sta nel fatto di prolungare la vita del paraolio preservando l'integrità delle caratteristiche fondamentali di resistenza chimica ed elastica. Per questo motivo in tutte le nostre confezioni di **ARI FORK OIL SEALS** includiamo una bustina monodose di ARISIL che serve per il corretto montaggio dei 2 paraolio.

## ARISIL special oil seal lubricant

**ARI** fork oil seals are made from a rubber compound specifically developed to work with the lubricants used in front forks, with all their various additives. This compound is completely different from that normally used for rotating shaft seals, since the physical environment inside a fork with its reciprocating movement, and the specialist lubricants, are completely different. We have designed **ARI** oil seals with a variety of lip profiles to make them longer lasting, while reducing to a minimum the friction effect against the moving shaft. Over the years, we have discovered the key role of a separating lubricant between the fork tube and the rubber of the oil seal to reduce to a minimum the surface friction, without affecting the function of the oil seal. After exhaustive testing, we have chosen a lubricant which is produced in the USA, and devised specifically as a rubber/metal lubricant for mechanical components used in the NASA space program. The advantage of this special grease, which we call ARISIL, is that it extends the life of the oil seal, and helps it retain its vital characteristics of flexibility and chemical resistance. For this reason, every set of **ARI FORK OIL SEALS** contains a single dose sachet of **ARISIL**, sufficient to lubricate the two oil seals supplied.

## ARISIL la grasa especial para retenes

Los retenes de horquilla **ARI** se han fabricado con un tipo de goma resistente a los aditivos que llevan los aceites de suspensión. Esta mezcla es completamente diferente de la que pueda utilizarse para los retenes de cigueñal, ya que debe resistir de una forma diferente la agresión química causada por el aceite, así como el trabajo mecánico en el sentido longitudinal propio de la suspensión. Nuestros retenes **ARI** se han proyectado, además, con estructuras en el borde del labio diferentes para mejorar la resistencia y al mismo tiempo reducir el máximo posible la fricción de la barra en el interior del reten. La experiencia ha demostrado que es necesario un lubricante separador entre la barra y el reten, su misión es reducir la fricción sin deteriorar la estanqueidad de la junta. Para resolver este problema probamos diversos componentes grasos, el escogido fue una grasa silicona, producida en los U.S.A. y especialmente estudiada como aplicación para goma - metal de los órganos mecánicos de los vehículos espaciales de la N.A.S.A. Las ventajas de esta grasa, que hemos denominado **ARISIL**, reside en el factor que permite alargar la vida del retén preservando la integridad de las características fundamentales de resistencia química y elástica. Por este motivo hemos incluido en todos nuestros kits de reparación **ARI FORK OIL SEALS**, una bolsa de **ARISIL** que sirve para montar de forma correcta los dos retenes.

## TYPICAL CHARACTERISTICS

Product type:	<b>GREASE</b>
Colour:	<b>WHITE</b>
Composition:	<b>SILICONE LUBRICANT WITH ADDITIVES</b>
Temperature range	<b>-65° degrees c =&gt; +175° degrees c</b>
Coefficient of friction	<b>0.003 - load 6.3 n at 10 mm per second 24h</b>
USA military specification	<b>G-4343 C</b>



10945 1 gr. - 0,03527 ounces



12950 100 gr. - 3,527 ounces

Questo attrezzo per montare correttamente i paraolio su forcelle tradizionali e rovesciate (upside down) è disponibile per paraolio da 35 a 51 mm di diametro interno. Ricavato dal pieno è in acciaio con trattamento galvanico anticorrosione ed ha una superficie esterna lavorata per una presa sicura. Il peso è tra gli 800 ed i 1000 grammi a seconda delle misure. Viene venduto singolarmente.

*The Split fork seal driver is a tool used for changing the fork seals on conventional and upside down forks. Available for fork seals in 35 mm thru 51 mm configurations. Manufactured from plated carbon steel, featuring split design and weighted body. Weight range from 800 to 1.000 gr. Sold individually.*

*Este útil para el montaje correcto de los retenes en horquillas tradicionales e invertidas (upside down) está disponible para retenes de 35 a 51 mm de diámetro interno. Realizado a partir de un bloque de acero mecanizado, con un tratamiento anticorrosión, posee una superficie externa que permite un perfecto agarre. El peso está comprendido entre 800 y 1000 grs. Se vende por unidades.*

CODE	TUBE Ø mm	CODE	TUBE Ø mm
12930/35	Ø 35	12930/44	Ø 44
12930/36	Ø 36	12930/45	Ø 45
12930/37	Ø 37	12930/46	Ø 46
12930/38	Ø 38	12930/47	Ø 47
12930/39	Ø 39	12930/48	Ø 48
12930/40	Ø 40	12930/49	Ø 49
12930/41	Ø 41	12930/50	Ø 50
12930/42	Ø 42	12930/51	Ø 51
12930/43	Ø 43		

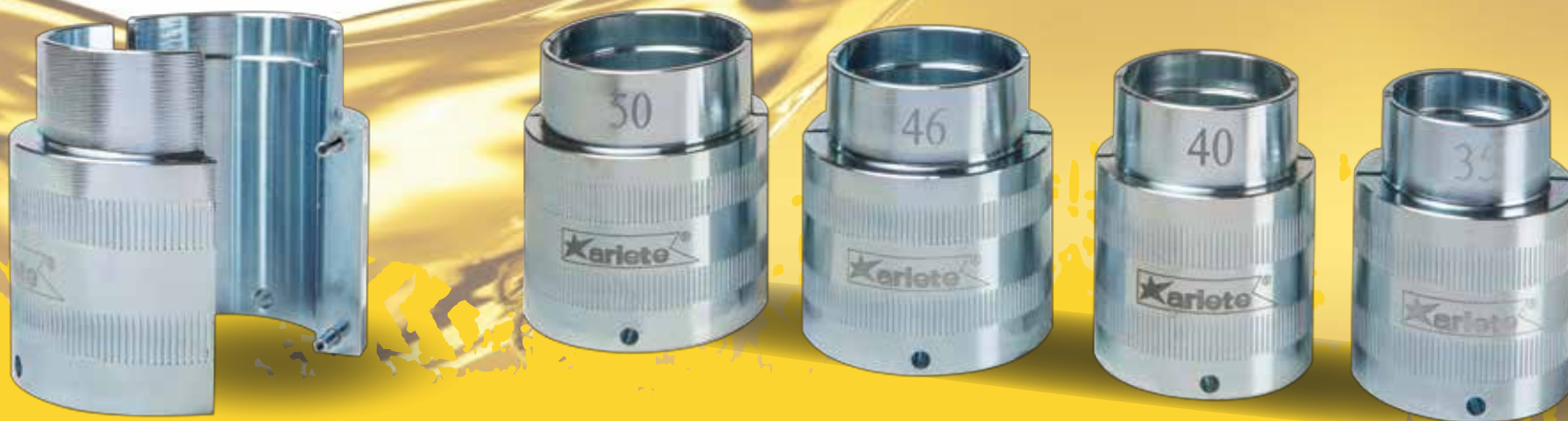

# ARI

RED = DUST SEALS - ROSSO = PARAPOLVERE ROJO = GUARDAPOLVO

LIST BY SIZE

SIZE	TYPE	CODE	SIZE	TYPE	CODE
24 x 32 x 7/7,5	KCY	ARI.110	33 x 46 x 10,5	TC4	ARI.004
25,7 x 37 x 10,5	TC4	ARI.075	33 x 46 x 11	DCY	ARI.073
<b>26 x 35,5/37,7 x 6/13,5</b>	<b>Y</b>	<b>ARI.076</b>	33 x 46 x 11	DC4	ARI.096
26 x 37 x 10,5	TC4	ARI.052	<b>33 x 46,5/53 x 5,8/15</b>	<b>XICY</b>	<b>ARI.140</b>
27 x 39 x 10,5	TC4	ARI.009	<b>33,34 x 49,21 x 12,7/17,5</b>	TCY	ARI.038
28 x 38 x 7	SC	ARI.010	34 x 46 x 10,5	TB4	ARI.002
28 x 40 x 8	TC4	ARI.111	35 x 46 x 11	DC4Y-2	ARI.149
28,5 x 40 x 7/11	TC3Y	ARI.160	<b>35 x 46,8/51,3 x 5/12,5</b>	<b>SG5Y</b>	<b>ARI.148</b>
29 x 41 x 11	DCY	ARI.055	35 x 47 x 10	DCY	ARI.040
29,8 x 40 x 7	TC4	ARI.098	35 x 47 x 10/10,5	TCL	ARI.022
30 x 39/43 x 12	DG5Y	ARI.112	35 x 47 x 7,5/10	DCY	ARI.066
30 x 40 x 7/8	KCY	ARI.080	35 x 47 x 7/9	TCY	ARI.012
30 x 40 x 7/9	TCY	ARI.020	35 x 47 x 9,5/10,5	TC4Y	ARI.051
30 x 40 x 8/12	TC6YI	ARI.113	35 x 48 x 10,5	TC4	ARI.024
30 x 40 x 8/9	TCY	ARI.079	35 x 48 x 11	DCY	ARI.003T
30 x 40,5 x 10,5/12	TCL	ARI.048	35 x 48 x 13/14,5	TCL	ARI.003R
30 x 42 x 10,5	TB4	ARI.016	35 x 48 x 8/10,5	TCL	ARI.061
30 x 42 x 8/11	DCY1	ARI.142	35 x 48 x 8/9,5	TCY	ARI.049
31 x 43 x 10,5	DCY	ARI.005	35 x 48,2 x 8/10,2	DC4Y	ARI.141
31,5 x 45 x 7,1	TG4	ARI.161	<b>35 x 48,5/53 x 5,8/15</b>	<b>XICY</b>	<b>ARI.130</b>
31,7 x 42 x 7/9	TCL	ARI.078	36 x 46 x 7/9	TCY	ARI.043
31,74 x 42 x 9	TC4	ARI.103	36 x 48 x 10,5	TC4	ARI.001
<b>31,75 x 42,8/48 x 7,6/11,6 + 31,7 x 42 x 7/9</b>	<b>Y+TCL</b>	<b>ARI.077</b>	36 x 48 x 11	TC4-1	ARI.114
31,8 x 42 x 7	TC4	ARI.133	36 x 48 x 11/12,5	TCL	ARI.025
32 x 42 x 7	SC	ARI.013	36 x 48 x 8/9,5	TCL	ARI.046
32 x 42 x 7/9	TCY	ARI.011	<b>36 x 48,5/52,5 x 6/14</b>	<b>Y</b>	<b>ARI.115</b>
32 x 42 x 8/9	TCY	ARI.014	37 x 49 x 8/10	DCY	ARI.050
32 x 43 x 12,5	TB4	ARI.031	37 x 49/49,4 x 8/9,5	TCL	ARI.027
32 x 44 x 10,5	TC4	ARI.060	37 x 50 x 11	DCY	ARI.044
32 x 45 x 7	TC	ARI.122	<b>37 x 50,5 x 5,6/12,8</b>	<b>Y-2</b>	<b>ARI.162</b>
32 x 45 x 9/11	TCL	ARI.074	37,8 x 48 x 6/6,5	TCY	ARI.017
33 x 43 x 6,5/7,5	TCL	ARI.015	38 x 48 x 10	TC4	ARI.094
33 x 45 x 10	TC4	ARI.135	<b>38 x 49,1/54 x 6/15,5</b>	<b>Y</b>	<b>ARI.092</b>
33 x 45 x 11	TC4	ARI.101	38 x 50 x 10,5	TC4	ARI.021
33 x 45 x 8/10,5	TCL	ARI.071	38 x 50 x 11	TC4	ARI.062
33 x 45 x 8/10,5	DC4Y	ARI.100	38 x 50 x 7/8	TCL	ARI.029
<b>33 x 45,5/49,7 x 4,5/13,8</b>	<b>Y</b>	<b>ARI.121</b>	38 x 50 x 8/9,5	TCY	ARI.032

**RED = DUST SEALS - ROSSO = PARAPOLVERE ROJO = GUARDAPOLVO** **ARI**

SIZE	TYPE	CODE	SIZE	TYPE	CODE
38 x 52 x 11	DCY	ARI.059	43 x 54,3 x 5/15,4	Y	ARI.155
38,5 x 48 x 7/8,7	TBCL	ARI.084	43 x 54,3 x 6/13	Y-1	ARI.152
39 x 51 x 10,5/12	TCL	ARI.070	43 x 54,4 x 4,6/14	Y	ARI.119
39 x 51 x 8/10,5	TCL	ARI.058	43 x 55 x 10,5/12	TCL	ARI.036
39 x 51 x 8/9,5 + 39 x 51,1/55,6 x 4,7/11,5	TCL+Y	ARI.068	43 x 55 x 11	TC4	ARI.123
39 x 51,5 x 4,8/14	XICY	ARI.154	43 x 55 x 11/14	TCL	ARI.127
39 x 52 x 11	DCY	ARI.037	43 x 55 x 9,5/10,5	TCL	ARI.072
40 x 49,5 x 7/9,5	DC4Y	ARI.035	43 x 55 x 9,5/10,5	DC4Y	ARI.109
40 x 52 x 10/10,5	TCL	ARI.023	43 x 55,7/60 x 5/14	XICY	ARI.144
40 x 52 x 8/10,5	TCL	ARI.063	45 x 57 x 11	DCY	ARI.067
40 x 52 x 8/9,5	TCY	ARI.033	45 x 57,3/62 x 6/13	SG5Y	ARI.091
40 x 52,5 x 4,6/14	Y	ARI.124	45 x 58 x 11	DCY	ARI.120
41 x 51 x 6	SC4	ARI.045	45 x 58 x 8,5/11	DG4Y	ARI.082
41 x 52,2 x 11	DCY1	ARI.143	45 x 58,3/62,3 x 4,5/11	Y-9	ARI.081
41 x 52,5 x 4,6/14	Y-2	ARI.150	46 x 58 x 10,5	DC4	ARI.108
41 x 53 x 10,5	TC4	ARI.041	46 x 58 x 8,5/11,5	DC4Y-1	ARI.146
41 x 53 x 11	TC4	ARI.132	46 x 58,1 x 9,5/11,5	DCY	ARI.087
41 x 53 x 8/10,5	TCL	ARI.057	46 x 58,5 x 5/10	YC	ARI.131
41 x 53 x 8/10,5	DC	ARI.102	46 x 58,5/62,3 x 5,8/13,2	Y-9	ARI.147
41 x 53 x 8/9,5	TCY	ARI.056	46 x 58,5/62,5 x 5/11,5	Y	ARI.088
41 x 53,5/58 x 4,8/14	XICY	ARI.138	47 x 58 x 10	TC4	ARI.105
41 x 53,7 x 5/10	YC	ARI.128	47 x 58,5/62 x 6/10,3	SG5	ARI.106
41 x 54 x 11	DCY	ARI.047	48 x 57,7 x 9,5/10,3	TCL1	ARI.116
41 x 54 x 5,6/12,7	Y-24	ARI.151	48 x 57,91 x 9,5/11,5	DC4Y	ARI.139
41 x 54,3 x 5,8/15	Y	ARI.153	48 x 58 x 9/9,8	TCL1	ARI.145
41,3 x 54 x 13/14	TACY-6	ARI.089	48 x 58,2 x 8,5/10,5	DC4Y	ARI.117
41,7 x 55 x 10/10,5	TCL	ARI.028	48 x 58,5/62 x 6/11,5	Y-1	ARI.126
41,7 x 55 x 7,5/10	DCY	ARI.083	48 x 61 x 11	TC4	ARI.134
41,7 x 55 x 8/10,5	TC4Y	ARI.034	48 x 61/65 x 6,3/15	Y-2	ARI.165
42 x 55,5 x 6/11	VCY	ARI.164	49 x 60 x 10	TC4	ARI.104
43 x 52,7 x 9,5/10,5	TCY	ARI.107	49 x 60,5 x 6/10,5	Y-1	ARI.163
43 x 52,9 x 9,2	DC4Y-1	ARI.158	50 x 59,6 x 7/10,5	DC4Y	ARI.085
43 x 53,4 x 6/13	Y-1	ARI.159	50 x 60/63 x 7/13	Y	ARI.086
43 x 54 x 11	TC4	ARI.053	50 x 62 x 9,5/11,5	DC4Y	ARI.125
43 x 54 x 11	DCY	ARI.118	50 x 63 x 11	TGY	ARI.093
43 x 54 x 9,5/10,5	TCL	ARI.090	50 x 63 x 11	DCY	ARI.136
43 x 54,2/59,8 x 6/11	Y-11	ARI.129	50 x 63,4 x 4,6/14	SG5Y	ARI.137

**ARI**  
**UN**  
**NI**  
**S**  
**Y**  
**B**  
**T**  
**S**  
**F**  
**103**

# MX APPLICATION LIST

X No Bks - Not Available

BIKE	2016	2015	2014	2013	2012	2011	2010	2009	2008	2007	2006	2005	2004	2003	2002	2001	2000	1999	1998	1997	1996	
<b>Honda CR</b>																						
80-85	x	x	x	x	x	x	x	x	ARI.044	ARI.044	ARI.044	ARI.044	ARI.044	ARI.044	ARI.044	ARI.044	ARI.044	ARI.044	ARI.044	ARI.044	ARI.044	
CAP	x	x	x	x	x	x	x	x	ARI.162	ARI.162	ARI.162	ARI.162	ARI.162	ARI.162	ARI.162	ARI.162	ARI.162	ARI.162	ARI.162	ARI.162	ARI.162	
125	x	x	x	x	x	x	x	x	x	ARI.108	ARI.108	ARI.108	ARI.087	ARI.087	ARI.087	ARI.087	ARI.087	ARI.087	ARI.087	ARI.087	ARI.087	
CAP	x	x	x	x	x	x	x	x	x	ARI.131	ARI.131	ARI.131	ARI.088	ARI.088	ARI.088	ARI.088	ARI.088	ARI.088	ARI.088	ARI.088	-	
250	x	x	x	x	x	x	x	x	x	ARI.105	ARI.105	ARI.105	ARI.105	ARI.105	ARI.105	ARI.105	ARI.105	ARI.105	ARI.105	ARI.105	ARI.087	
CAP	x	x	x	x	x	x	x	x	x	ARI.106	ARI.106	ARI.106	ARI.106	ARI.106	ARI.106	ARI.106	ARI.106	ARI.106	ARI.106	ARI.106	ARI.088	
250/F	ARI.104	ARI.104	ARI.117	ARI.117	ARI.117	ARI.117	ARI.117	ARI.105	ARI.105	ARI.105	ARI.105	ARI.105	ARI.105	x	x	x	x	x	x	x	x	
CAP	ARI.163	ARI.163	ARI.126	ARI.126	ARI.126	ARI.126	ARI.126	ARI.106	ARI.106	ARI.106	ARI.106	ARI.106	ARI.106	x	x	x	x	x	x	x	x	
450	x	x	x	x	X	X	X	X	X	x	x	x	x	x	x	ARI.087	ARI.087	ARI.087	ARI.087	ARI.087	ARI.087	
CAP	x	x	x	x	X	X	X	X	X	x	x	x	x	x	x	ARI.088	ARI.088	ARI.088	ARI.088	ARI.088	ARI.088	
450/F	ARI.117	ARI.117	ARI.117	ARI.117	ARI.145	ARI.145	ARI.145	ARI.117	ARI.105	ARI.105	ARI.105	ARI.105	ARI.105	ARI.105	ARI.105	x	x	x	x	x	x	
CAP	ARI.126	ARI.126	ARI.126	ARI.126	ARI.126	ARI.126	ARI.126	ARI.126	ARI.106	ARI.106	ARI.106	ARI.106	ARI.106	ARI.106	ARI.106	x	x	x	x	x	x	
500	x	x	x	x	x	x	x	x	x	x	x	x	ARI.105	ARI.105	ARI.105	ARI.087	ARI.087	ARI.087	ARI.087	ARI.087	ARI.087	
CAP	x	x	x	x	x	x	x	x	x	x	x	x	ARI.106	ARI.106	ARI.106	ARI.088	ARI.088	ARI.088	ARI.088	ARI.088	ARI.088	
<b>Yamaha YZ-WR</b>																						
85	ARI.046	ARI.046	ARI.046	ARI.046	ARI.046	ARI.046	ARI.046	ARI.046	ARI.046	ARI.046	ARI.046	ARI.046	ARI.046	ARI.046	ARI.046	x	x	x	x	X	x	
CAP	-	-	-	-	-	-	-	-	-	-	-	-	-	-	-	x	x	x	x	X	x	
125 LC	ARI.145	ARI.145	ARI.145	ARI.117	ARI.117	ARI.117	ARI.117	ARI.117	ARI.117	ARI.117	ARI.117	ARI.117	ARI.117	ARI.087	ARI.087	ARI.087	ARI.087	ARI.087	ARI.087	ARI.087	ARI.087	
CAP	ARI.126	ARI.126	ARI.126	ARI.126	ARI.126	ARI.126	ARI.126	ARI.126	ARI.126	ARI.126	ARI.126	ARI.126	ARI.126	ARI.088	ARI.088	ARI.088	ARI.088	ARI.088	ARI.088	ARI.088	ARI.088	
250 LC	ARI.145	ARI.145	ARI.117	ARI.117	ARI.117	ARI.117	ARI.117	ARI.117	ARI.117	ARI.117	ARI.117	ARI.117	ARI.117	ARI.087	ARI.087	ARI.087	ARI.087	ARI.087	ARI.087	ARI.087	ARI.087	
CAP	ARI.126	ARI.126	ARI.126	ARI.126	ARI.126	ARI.126	ARI.126	ARI.126	ARI.126	ARI.126	ARI.126	ARI.126	ARI.126	ARI.088	ARI.088	ARI.088	ARI.088	ARI.088	ARI.088	ARI.088	ARI.088	
250/F	ARI.145	ARI.145	ARI.145	ARI.145	ARI.145	ARI.145	ARI.145	ARI.117	ARI.117	ARI.117	ARI.117	ARI.117	ARI.117	x	x	x	x	x	x	x	x	
CAP	ARI.126	ARI.126	ARI.126	ARI.126	ARI.126	ARI.126	ARI.126	ARI.126	ARI.126	ARI.126	ARI.126	ARI.126	ARI.126	x	x	x	x	x	x	x	x	
400	x	x	x	x	x	x	x	x	x	x	x	x	x	ARI.087	ARI.087	ARI.087	ARI.087	ARI.087	ARI.087	ARI.087	x	
CAP	x	x	x	x	x	x	x	x	x	x	x	x	x	ARI.088	ARI.088	ARI.088	ARI.088	ARI.088	ARI.088	ARI.088	x	
426	x	x	x	x	x	x	x	x	x	x	x	x	x	ARI.087	ARI.087	ARI.087	ARI.087	ARI.087	ARI.087	ARI.087	x	
CAP	x	x	x	x	x	x	x	x	x	x	x	x	x	ARI.088	ARI.088	ARI.088	ARI.088	ARI.088	ARI.088	ARI.088	x	
450/F	ARI.145	ARI.145	ARI.145	ARI.145	ARI.145	ARI.145	ARI.145	ARI.117	ARI.117	ARI.117	ARI.117	ARI.117	ARI.117	x	x	x	x	x	x	x	x	
CAP	ARI.126	ARI.126	ARI.126	ARI.126	ARI.126	ARI.126	ARI.126	ARI.126	ARI.126	ARI.126	ARI.126	ARI.126	ARI.126	x	x	x	x	x	x	x	x	
<b>Kawasaki KX</b>																						
60	x	x	x	x	x	x	x	x	x	x	x	x	x	ARI.016	ARI.016	ARI.016	ARI.016	ARI.016	ARI.016	ARI.016	ARI.016	
CAP	x	x	x	x	x	x	x	x	x	x	x	x	x	-	-	-	-	-	-	-	-	
65	ARI.096	ARI.096	ARI.096	ARI.096	ARI.096	ARI.096	ARI.096	ARI.096	ARI.096	ARI.096	ARI.096	ARI.096	ARI.096	ARI.096	ARI.096	ARI.096	ARI.096	x	x	x	x	
CAP	-	-	-	-	-	-	-	-	-	-	-	-	-	-	-	-	-	x	x	x	x	
80/85	ARI.046	ARI.046	ARI.046	ARI.046	ARI.046	ARI.046	ARI.046	ARI.046	ARI.046	ARI.046	ARI.046	ARI.046	ARI.046	ARI.046	ARI.046	ARI.046	ARI.046	ARI.046	ARI.046	ARI.046	ARI.046	
CAP	-	-	-	-	-	-	-	-	-	-	-	-	-	-	-	-	-	-	-	-	-	
100	ARI.046	ARI.046	ARI.046	ARI.046	ARI.046	ARI.046	ARI.046	ARI.046	ARI.046	ARI.046	ARI.046	ARI.046	ARI.046	ARI.046	ARI.046	ARI.046	ARI.046	ARI.046	ARI.046	ARI.046	ARI.046	
CAP	-	-	-	-	-	-	-	-	-	-	-	-	-	-	-	-	-	-	-	-	-	

# X No Bike - Not Available **MX APPLICATION LIST**

BIKE	2016	2015	2014	2013	2012	2011	2010	2009	2008	2007	2006	2005	2004	2003	2002	2001	2000	1999	1998	1997	1996
<b>Kawasaki KX</b>																					
125/250	x	x	x	x	x	x	x	x	ARI.117	ARI.117	ARI.117	ARI.117	ARI.117	ARI.117	ARI.117	ARI.087	ARI.087	ARI.087	ARI.087	ARI.087	ARI.087
CAP	x	x	x	x	x	x	x	x	ARI.126	ARI.126	ARI.126	ARI.126	ARI.126	ARI.126	ARI.126	ARI.088	ARI.088	ARI.088	ARI.088	ARI.088	ARI.088
250/F	ARI.117	ARI.117	ARI.117	ARI.117	ARI.105	ARI.105	ARI.105	ARI.105	ARI.105	ARI.105	ARI.105	ARI.117	x	x	x	x	x	x	x	x	x
CAP	ARI.126	ARI.126	ARI.126	ARI.126	ARI.106	ARI.106	ARI.106	ARI.106	ARI.106	ARI.106	ARI.106	ARI.126	x	x	x	x	x	x	x	x	x
450/F	ARI.104	ARI.104	ARI.145	ARI.145	ARI.145	ARI.145	ARI.145	ARI.117	ARI.117	ARI.117	ARI.117	x	x	x	x	x	x	x	x	x	x
CAP	ARI.163	ARI.163	ARI.126	ARI.126	ARI.126	ARI.126	ARI.126	ARI.126	ARI.126	ARI.126	ARI.126	x	x	x	x	x	x	x	x	x	x
<b>Suzuki RM</b>																					
80/85	ARI.044	ARI.044	ARI.044	ARI.044	ARI.044	ARI.044	ARI.044	ARI.044	ARI.044	ARI.044	ARI.044	ARI.044	ARI.044	ARI.044	ARI.044	ARI.044	ARI.044	x	x	x	x
CAP	ARI.162	ARI.162	ARI.162	ARI.162	ARI.162	ARI.162	ARI.162	ARI.162	ARI.162	ARI.162	ARI.162	ARI.162	ARI.162	ARI.162	ARI.162	ARI.162	ARI.162	x	x	x	x
125	x	x	x	x	ARI.105	ARI.105	ARI.105	ARI.105	ARI.105	ARI.105	ARI.105	ARI.105	ARI.105	ARI.105	ARI.105	ARI.105	ARI.104	ARI.104	ARI.104	ARI.104	ARI.104
CAP	x	x	x	x	ARI.106	ARI.106	ARI.106	ARI.106	ARI.106	ARI.106	ARI.106	ARI.106	ARI.106	ARI.106	ARI.106	ARI.106	ARI.163	ARI.163	ARI.163	ARI.163	ARI.163
250	x	x	x	x	x	x	x	x	ARI.105	ARI.105	ARI.105	ARI.105	ARI.105	ARI.105	ARI.105	ARI.105	ARI.104	ARI.104	ARI.104	ARI.104	ARI.104
CAP	x	x	x	x	x	x	x	x	ARI.106	ARI.106	ARI.106	ARI.106	ARI.106	ARI.106	ARI.106	ARI.106	ARI.163	ARI.163	ARI.163	ARI.163	ARI.163
250/Z	ARI.117	ARI.117	ARI.117	ARI.117	ARI.105	ARI.105	ARI.105	ARI.105	ARI.105	ARI.105	ARI.117	ARI.105	ARI.105	ARI.105	x	x	x	x	x	x	x
CAP	ARI.126	ARI.126	ARI.126	ARI.126	ARI.106	ARI.106	ARI.106	ARI.106	ARI.106	ARI.106	ARI.126	ARI.106	ARI.106	ARI.106	x	x	x	x	x	x	x
450/Z	ARI.104	ARI.104	ARI.117	ARI.117	ARI.105	ARI.105	ARI.105	ARI.105	ARI.105	ARI.105	ARI.105	x	x	x	x	x	x	x	x	x	x
CAP	ARI.163	ARI.163	ARI.126	ARI.126	ARI.106	ARI.106	ARI.106	ARI.106	ARI.106	ARI.106	ARI.106	x	x	x	x	x	x	x	x	x	x
<b>Ktm SX</b>																					
125	ARI.139	ARI.139	ARI.139	ARI.139	ARI.139	ARI.139	ARI.139	ARI.116	ARI.116	ARI.107	ARI.116	ARI.116	ARI.116	ARI.116	ARI.116	ARI.116	ARI.107	ARI.082	ARI.082	ARI.082	ARI.082
CAP	ARI.126	ARI.126	ARI.126	ARI.126	ARI.126	ARI.126	ARI.126	ARI.126	ARI.126	-	ARI.126	ARI.126	ARI.126	ARI.126	ARI.126	ARI.126	-	ARI.081	ARI.081	ARI.081	ARI.081
250	ARI.139	ARI.139	ARI.139	ARI.139	ARI.139	ARI.139	ARI.139	ARI.116	ARI.116	ARI.116	ARI.116	ARI.116	ARI.116	ARI.116	ARI.116	ARI.116	ARI.107	ARI.085	ARI.085	ARI.085	ARI.085
CAP	ARI.126	ARI.126	ARI.126	ARI.126	ARI.126	ARI.126	ARI.126	ARI.126	ARI.126	ARI.126	ARI.126	ARI.126	ARI.126	ARI.126	ARI.126	ARI.126	-	ARI.086	ARI.086	ARI.086	ARI.086
400/450/525	ARI.139	ARI.139	ARI.139	ARI.139	ARI.139	ARI.139	ARI.139	ARI.116	ARI.116	ARI.116	ARI.116	ARI.116	ARI.116	ARI.116	ARI.116	ARI.116	ARI.107	ARI.085	ARI.085	ARI.085	ARI.085
CAP	ARI.126	ARI.126	ARI.126	ARI.126	ARI.126	ARI.126	ARI.126	ARI.126	ARI.126	ARI.126	ARI.126	ARI.126	ARI.126	ARI.126	ARI.126	ARI.126	-	ARI.086	ARI.086	ARI.086	ARI.086
<b>Husqvarna TC</b>																					
85	ARI.139	ARI.139	x	x	x	x	x	x	x	x	x	x	x	x	x	x	x	x	x	x	x
CAP	ARI.126	ARI.126	x	x	x	x	x	x	x	x	x	x	x	x	x	x	x	x	x	x	x
125	ARI.139	ARI.139	ARI.139	ARI.139	x	x	x	x	x	x	x	x	x	x	x	x	x	x	x	x	x
CAP	ARI.126	ARI.126	ARI.126	ARI.126	x	x	x	x	x	x	x	x	x	x	x	x	x	x	x	x	x
250	ARI.139	ARI.139	ARI.139	ARI.139	x	x	x	x	x	x	x	x	x	x	x	x	x	x	x	x	x
CAP	ARI.126	ARI.126	ARI.126	ARI.126	x	x	x	x	x	x	x	x	x	x	x	x	x	x	x	x	x
<b>Husqvarna FC</b>																					
250	ARI.139	ARI.139	ARI.139	ARI.139	x	x	x	x	x	x	x	x	x	x	x	x	x	x	x	x	x
CAP	ARI.126	ARI.126	ARI.126	ARI.126	x	x	x	x	x	x	x	x	x	x	x	x	x	x	x	x	x
350	ARI.139	ARI.139	ARI.139	ARI.139	x	x	x	x	x	x	x	x	x	x	x	x	x	x	x	x	x
CAP	ARI.126	ARI.126	ARI.126	ARI.126	x	x	x	x	x	x	x	x	x	x	x	x	x	x	x	x	x
450	ARI.139	ARI.139	ARI.139	ARI.139	x	x	x	x	x	x	x	x	x	x	x	x	x	x	x	x	x
CAP	ARI.126	ARI.126	ARI.126	ARI.126	x	x	x	x	x	x	x	x	x	x	x	x	x	x	x	x	x

# ACCESSORIES BRAKE CALIPER SEAL KITS

TECHNICAL



**EPDM HP**  
Special Compound



**GUARNIZIONI PINZE FRENO  
BRAKE CALIPERS SEAL KIT  
JUNTAS PINZAS DE FRENO**

## **EPDM HP** Special Compound

Tutti i componenti in gomma di questo kit, prodotti in Italia dalla Ariete, sono rettificati e testati singolarmente per garantire la perfezione della tenuta negli impianti frenanti.

**⚠ ATTENZIONE**  
Solo per liquido freni DOT 3 o DOT 4

The rubber brake seals in this kit are made in Italy by Ariete. After final grinding of the working surfaces, they are individually tested to guarantee their efficiency once fitted to the user's vehicle.

**⚠ WARNING**  
Use only DOT3 or DOT4 brake fluid

**Ariete** presenta una nuova linea di guarnizioni per pinze freno, per moto e scooters, quale ricambio non originale delle più diffuse marche presenti nel mercato. Il materiale utilizzato per le guarnizioni è una speciale miscela a base di **EPDM HP** messa a punto da Ariete e particolarmente resistente ai liquidi per freno più comunemente usati, DOT3 e DOT4.

Chiedere il catalogo specifico delle applicazioni ai vari modelli di moto e scooters.

**Ariete** introduces a new line of seal kits to suit brake calipers for motorcycles and scooters. These are after-market replacements which fit many of the most popular models on the market.

The material used for the seals is a special compound of **EPDM HP**, developed by Ariete and fully compatible with the most common brake fluids (DOT3 and DOT4).

Ask for our special catalogue covering applications for different models of motorcycles and scooters.

**Ariete** presenta una nueva línea de juntas para pinzas de freno para motos y scooters, como pieza de repuesto no original de las más difundidas marcas del mundo. El material usado para las juntas es una especial mezcla de **EPDM HP**, estudiada por Ariete y particularmente resistente a los líquidos para los frenos más comúnmente usados, como DOT3 y DOT4.

Pidan el catalogo específico de las aplicaciones a los varios modelos de motos y scooters.

# MASTER CYLINDER SEAL KITS

# ACCESSORIES



**EPDM HP**  
Special Compound



**GUARNIZIONI POMPA FRENO**  
**BRAKE MASTER-CYLINDERS SEAL KIT**  
**JUNTAS BOMBAS DE FRENO**

**Ariete** presenta una nuova linea di guarnizioni per pompe freno, per moto e scooters, quale ricambio non originale delle più diffuse marche presenti nel mercato. Il materiale utilizzato per le guarnizioni è una speciale miscela a base di **EPDM HP** messa a punto da Ariete e particolarmente resistente ai liquidi per freno più comunemente usati, DOT3 e DOT4.

Chiedere il catalogo specifico delle applicazioni ai vari modelli di moto e scooters.

**Ariete** introduces a new line of seal kits to suit brake master-cylinders for motorcycles and scooters. These are after-market replacements which fit many of the most popular models on the market. The material used for the seals is a special compound of **EPDM HP**, developed by Ariete and fully compatible with the most common brake fluids (DOT3 and DOT4).

Ask for our special catalogue covering applications for different models of motorcycles and scooters.

**Ariete** presenta una nueva línea de juntas para bombas de freno para motos y scooters, como pieza de repuesto no original de las más difundidas marcas del mundo. El material usado para las juntas es una especial mezcla de EPDM HP, estudiada por Ariete y particularmente resistente a los líquidos para los frenos más comúnmente usados, como DOT3 y DOT4.

Pidan el catalogo específico de las aplicaciones a los varios modelos de motos y scooters.

**ACCESSORIES**

**TECHNICAL**



Edgaro Barella - Photo D. Messora

**103**



## DOT3 - DOT4 FLUID PIPE

**12978/5** 6x10 mm Pack. 5 mt. - 16' 5" black

Tubo raccordo tra la pompa freno ed il serbatoio del liquido freni DOT3 - DOT4

Low-pressure hydraulic pipe to fit between remote reservoir and master cylinder, suits DOT3 - DOT4 fluid





















Tubo enlace con bomba de freno y deposito para liquido DOT3 - DOT4

























# TECHNICAL

# ACCESSORIES



Size	Code	Color	Pack	Use	Structure	Material
1,5 x 4	11949/10		10 mt. - 32' 10"	CARBURETTOR		
1,5 x 4	11949/10-T		10 mt. - 32' 10"	CARBURETTOR		
2 x 5	03998/10		10 mt. - 32' 10"	CARBURETTOR		
2 x 5	03998/10-T		10 mt. - 32' 10"	CARBURETTOR		
3 x 6	03999/10		10 mt. - 32' 10"	CARBURETTOR		
3 x 6	03999/10-T		10 mt. - 32' 10"	CARBURETTOR		
4 x 7	01925/10		10 mt. - 32' 10"			
4 x 7	01925/10-S		10 mt. - 32' 10"	UNLEADED FUEL	DOUBLE	
4 x 7	01925/10-V		10 mt. - 32' 10"			
4 x 7	01925-V		100 mt. - 328'			
4,5 x 9	01958/10		10 mt. - 32' 10"			
4,5 x 9	01958/10-V		10 mt. - 32' 10"			
4,5 x 9	01958-V		100 mt. - 328'			
4,8 x 9	11922/10-S		10 mt. - 32' 10"	UNLEADED FUEL	DOUBLE	
5 x 8	01922		100 mt. - 328'			
5 x 8	01922/10		10 mt. - 32' 10"			
5 x 8	01922/10-V		10 mt. - 32' 10"			
5 x 8	01922-V		100 mt. - 328'			
5,5 x 10	03904/10		10 mt. - 32' 10"			
5,5 x 10	03904/10-S		10 mt. - 32' 10"	UNLEADED FUEL	DOUBLE	
5,5 x 10	03904/10-V		10 mt. - 32' 10"			

# ACCESSORIES

Size	Code	Color	Pack	Use	Structure	Material
6 x 9	01958/A		100 mt. - 328'			
6 x 9	01958/A/10		10 mt. - 32' 10"			
6 x 9	01958/A10G		10 mt. - 32' 10"	UNLEADED FUEL	MONO	POLARLYS
6 x 9	01958/A10S		10 mt. - 32' 10"	UNLEADED FUEL	DOUBLE	
6 x 9	01958/A10V		10 mt. - 32' 10"			
6 x 9	01958/AG		100 mt. - 328'	UNLEADED FUEL	MONO	POLARLYS
6 x 9	01958/A-V		100 mt. - 328'			
6 x 9	09970/5		5 mt. - 16' 5"		DOUBLE	
6 x 9	13909/10EN		10 mt. - 32' 10"	E10 FUEL	DOUBLE	
6 x 9	13909/10EV		10 mt. - 32' 10"	E10 FUEL	DOUBLE	
6 X 13	01902/10		10 mt. - 32' 10"			
6 X 13	01902/10-V		10 mt. - 32' 10"			
6 X 13	01902-V		50 mt. - 164'			
6,5 X 11	11923/10-S		10 mt. - 32' 10"	UNLEADED FUEL	DOUBLE	
7 x 10	01922/A		100 mt. - 328'			
7 x 10	01922/A/10		10 mt. - 32' 10"			
7 x 10	01922/A10V		10 mt. - 32' 10"			
7 x 10	01922/A-V		100 mt. - 328'			
8 x 13	11932/10-V		10 mt. - 32' 10"			
8 x 13	13912/10EN		10 mt. - 32' 10"	E10 FUEL	DOUBLE	
8 x 13	13912/10EV		10 mt. - 32' 10"	E10 FUEL	DOUBLE	
10 x 15	11934/10-V		10 mt. - 32' 10"			



Gates è il produttore leader nella costruzione di cinghie ad alto contenuto tecnologico.

- La gomma è rinforzata dalla fibra aramidica per la miglior resistenza all'usura e per assicurare un perfetto accoppiamento con la puleggia del variatore.
- I più moderni trattamenti chimici dei cavi della cinghia, assicurano una perfetta adesione dei cavi alla gomma garantendo lunga vita alla cinghia e grande resistenza ai carichi pulsanti.
- Le mescole speciali di gomma offrono un'ottima resistenza alle alte ed alle basse temperature resistendo alle variazioni termiche.
- Il costante controllo dei processi produttivi assicura la massima accuratezza delle dimensioni delle cinghie.
- Costruite dalle fabbriche Gates in Europa, che sono tutte certificate per alta qualità, sicurezza e cura per l'ambiente.
- Nelle cinghie non sono presenti componenti chimici tossici in accordo con le direttive Europee.

Disponibili in tre versioni:

- 1) **STANDARD** la gomma è rinforzata con fibra aramidica.
- 2) **KEVLAR** cavi in fibra aramidica particolarmente tenace per resistere ai carichi ed alle accelerazioni.
- 3) **DOPPIA** costruzione a doppia dentellatura (Double Notch) per garantire il massimo delle prestazioni.

*Gates is a leading manufacturer of high-tech belts.*

- *Aramid fibre reinforced rubber compound, to better resist wear and ensure smooth sliding in the variator pulleys.*
- *Advanced chemical treatment of the tensile members, to assure improved bonding between cord and rubber and guarantee longer belt life and high shock resistance.*
- *Unique rubber compounds, to offer optimum resistance to the highest and lowest temperatures and to thermic load under friction.*
- *Consistent production processes, to ensure dimensional accuracy.*
- *Manufactured in Gates' European facilities, all certified to the highest quality and safety and environmental standards.*
- *No toxic chemical components, in compliance with the relevant European directives.*

Available in three different constructions:

- 1) **STANDARD** with aramid reinforced rubber compound.
- 2) **KEVLAR** extra strong aramid tensile members to maximise acceleration and shock load resistance.
- 3) **DOUBLE NOTCH** Double Notch construction to guarantee extra high performance.

*Gates es el productor líder en la construcción de correas con alto contenido tecnológico.*

- *La goma es reforzada por la fibra de aramida para una mejor resistencia al desgaste y para asegurar un perfecto acoplamiento con la polea del variador.*
- *Los más modernos tratamientos químicos de los cables de la correa aseguran una perfecta adhesión de los cables a la goma, garantizando una larga vida de la correa y una grande resistencia a los cargos pulsantes.*
- *Las mezclas especiales de goma ofrecen una excelente resistencia a las temperaturas altas y bajas, resistiendo a las variaciones térmicas.*
- *El constante control de los procesos de producción asegura el máximo primor de las dimensiones de las correas.*
- *Construida por las fabricas Gates en Europa, todas certificadas por el alto nivel de cualidad, seguridad y cuidado para el medio ambiente.*
- *En las correas no hay ningún componente químico toxico según las directivas europeas.*

Disponibles en tres versiones:

- 1) **ESTANDAR** la goma es reforzada con fibra de aramida.
- 2) **KEVLAR** cables de fibra de aramida particularmente tenaz para resistir a las cargas y a las aceleraciones.
- 3) **DOBLE** construcción con doble dentellado (Double Notch) para garantizar el máximo rendimiento.

# ACCESSORIES



**STANDARD**



**KEVLAR**

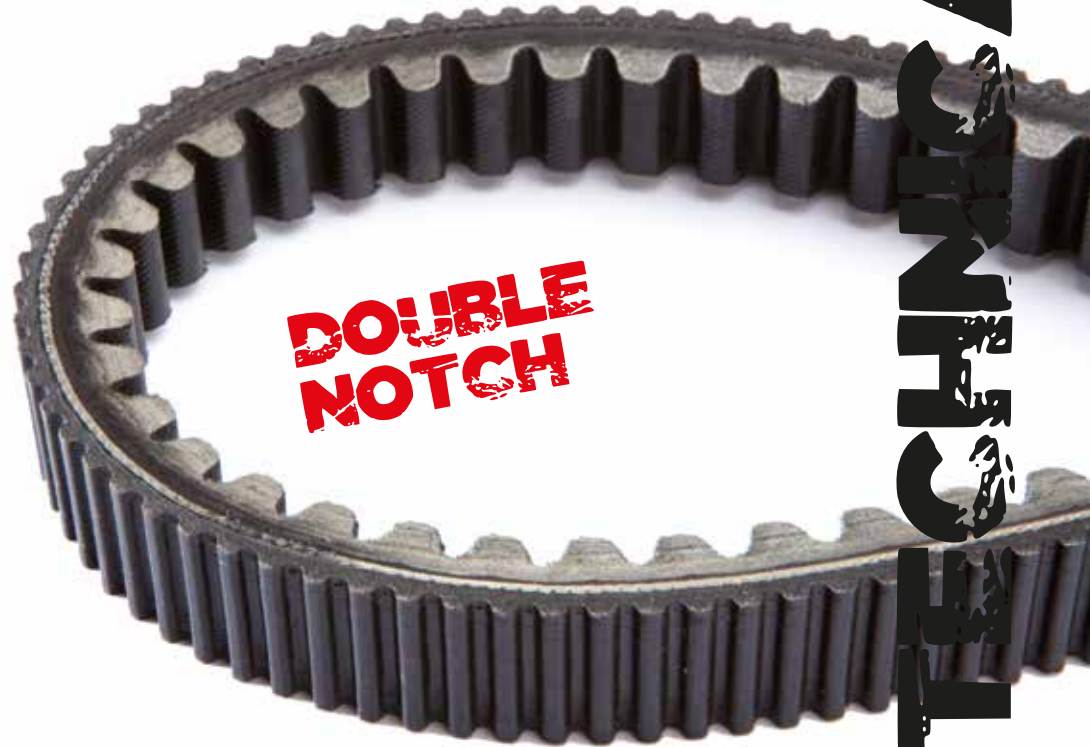

**DOUBLE  
NOTCH**

**TECHNICAL**

# MERCHANDISING

# ARJET



13908-A

13908-AR

13908-R

13908

Off-Road  
grips

Road  
grips



12932

12932-A

12932-AR

12932-R



12933-R

12933

12933-A

12933-AR



# MERCHANDISING

# ARIETE

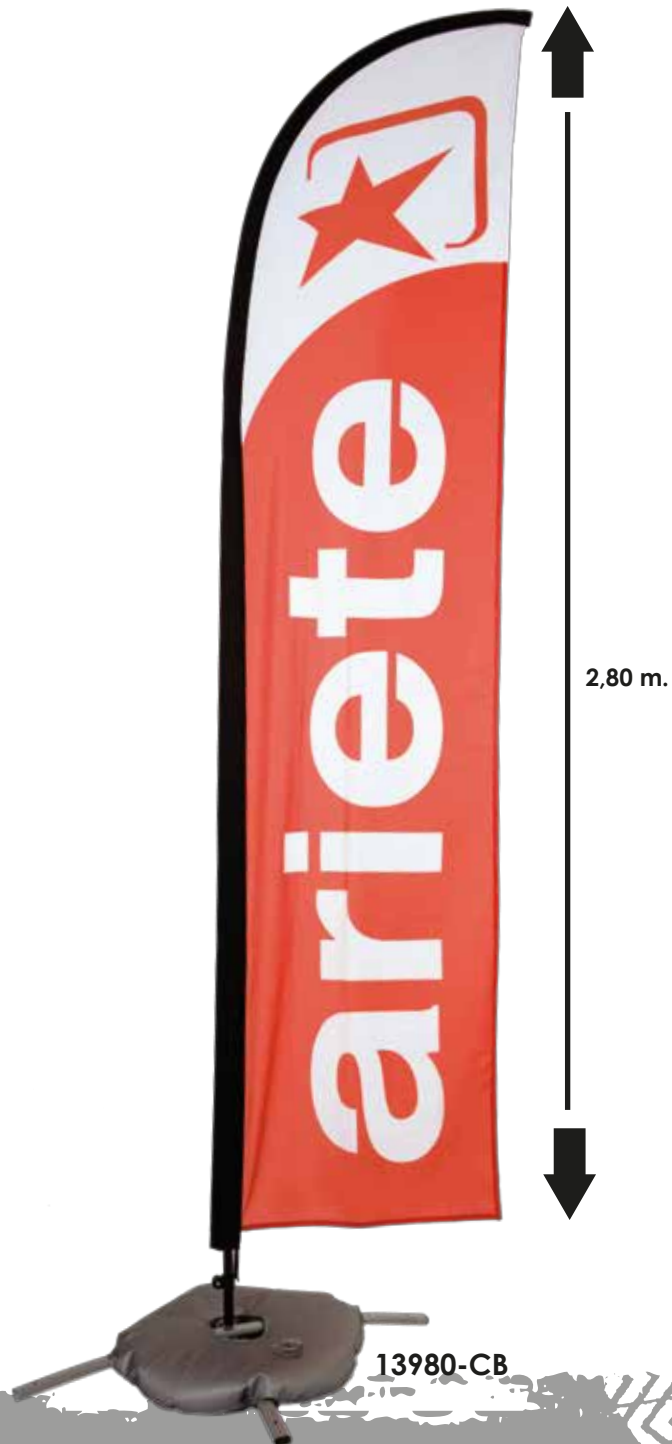

12965/A

## RACING GOGGLES CASE

- 1 tasca ampia per tear-offs con chiusura zip;
- 1 tasca aperta per le lenti;
- 3 tasche di dimensioni varie;
- 4 divisori interni rimovibili fissati con velcro;
- 1 large pocket with zip closure for tear-offs;
- 1 open pocket for lenses;
- 3 pockets in varied sizes;
- 4 removable internal dividers with Velcro;
- 1 bolsillo amplio con cremallera para tear-offs;
- 1 bolsillo abierto para lentes;
- 3 bolsillos interiores, distintos formatos;
- 4 divisorios removibles con velcro;



# MERCHANDISING

ARIETTA



12969-NG17



12969-NR17



12965-B



12971-B14  
Size S/M; 6 3/4"-7 1/4"

# MERCHANDISING

ARIETE



T-shirt VINTAGE



T-shirt MEMORIAL



T-shirt ARIETE



T-shirt RACING

FRONT



BACK

## T-shirt VINTAGE

- 14901-VM size M
- 14901-VL size L
- 14901-VXL size XL
- 14901-VXXL size XXL

## T-shirt MEMORIAL

- 14903-MM size M
- 14903-ML size L
- 14903-MXL size XL
- 14903-MXXL size XXL

## T-shirt ARIETE

- 14904-AM size M
- 14904-AL size L
- 14904-AXL size XL
- 14904-AXXL size XXL

## T-shirt RACING

- 14902-RM size M
- 14902-RL size L
- 14902-RXL size XL
- 14902-RXXL size XXL

# ARIES LIMITED EDITION

ARIES

70 anniversary  
1947-2017

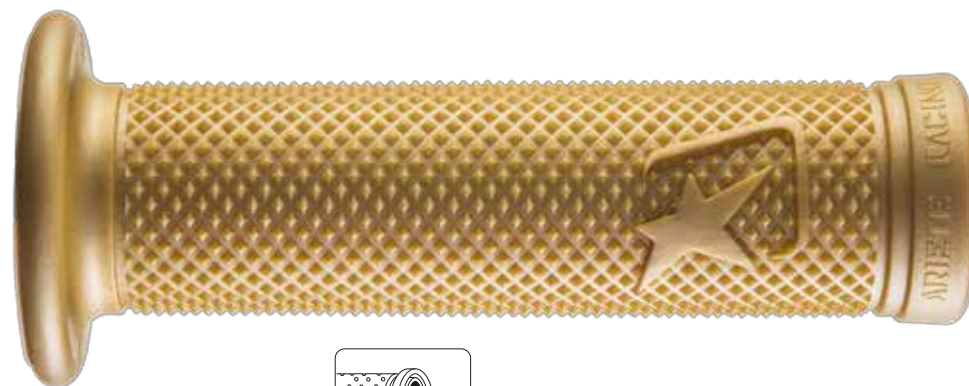
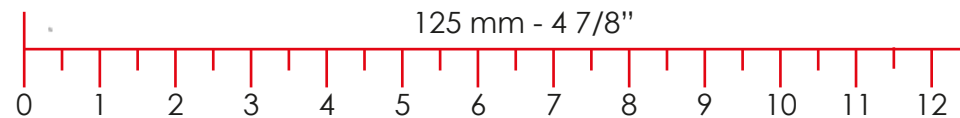

02636/GOLD

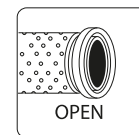

MEDIUM

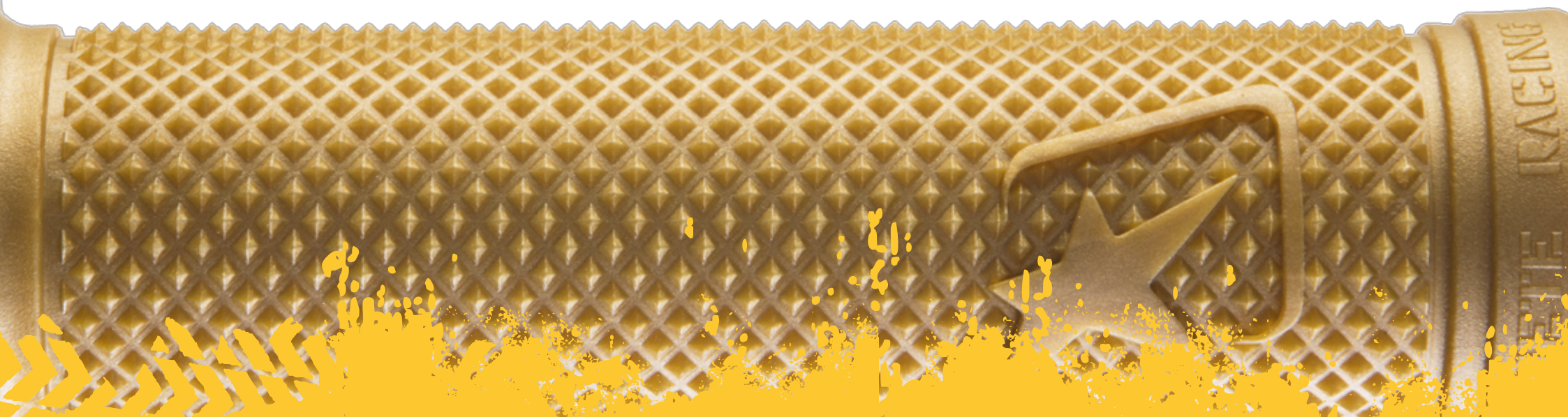

**LIMITED EDITION**

















**ARIETE**

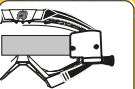
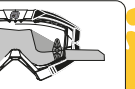



**13950-GOLD**  
**13953-GOLD ASIAN FITTING FOAM**



**Features**

-   
A.V.S.  
Ariete Ventilation System
-   
PU + PA
-   
ANTI\_FOG
-   
ANTI\_SCRATCH
-   
UV FILTERS
-   
OPEN FILTERS
-   
FOAM LAYERS  
3
-   
3D FOAM
-   
O.T.G.  
Over The Glasses
-   
LENS FOR ROLL\_OFF
-   
LENS FOR TEAR\_OFF
-   
QUICK RELEASE
-   
SILICONE
-   
DOUBLE BUCKLE
-   
CE
-   
NOSE GUARD  
INCLUDED
-   
MICROFIBER BAG  
INCLUDED
-   
ASIAN FITTING FOAM  
AVAILABLE

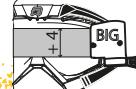
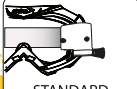
**Optional Accessories**

-   
BIG ROLL\_OFF
-   
STANDARD ROLL\_OFF
-   
One Size Fits All  
ARIETE LENS



# OVERVIEW

# GOOGLES

PRODUCT	CODE
 ARIETE	12960-ABIA
 ARIETE	12960-ANER
 ARIETE	12960-ABLU
 ARIETE	12960-ARED
 ARIETE	12960-ALIM
 ARIETE	12960-AORA

Ø7 LINE AAA

 PRR	14001-PRR
 PRA	14001-PRA
 PRO	14001-PRO
 PRL	14001-PRL
 PRN	14001-PRN
 PRB	14001-PRB

ADRENALINE PRIMS

PRODUCT	CODE
 CARB	12960-CARB
 COBA	12960-COBA
 CAGR	12960-CAGR
 CNBG	12960-CNBG
 CBGR	12960-CBGR

Ø7 COLORS

 RBRA	13950-RBRA 13953-RBRA <b>AFF</b>
 BNNG	13950-BNNG 13953-BNNG <b>AFF</b>
 BRGG	13950-BRGG 13953-BRGG <b>AFF</b>
 OBOB	13950-OBOB 13953-OBOB <b>AFF</b>
 ABAB	13950-ABAB 13953-ABAB <b>AFF</b>





RC BASIC







## RIDE AND ROLL KREW

 RRKB	13950-RRKB 13953-RRKB <b>AFF</b>
--	-------------------------------------

# OVERVIEW





# SELECTIONS

PRODUCT	CODE
	14001-SRRA
	14001-SAAB
	14001-SOOB
	14001-SNNG
	14001-SBGG

	13950-TBVG 13953-TBVG AFF
	13950-TNVF 13953-TNVF AFF
	13950-TGFO 13953-TGFO AFF
	13950-TBGF 13953-TBGF AFF
	13950-TAOF 13953-TAOF AFF
	13950-GOLD 13953-GOLD AFF

ADRENALINE SENIOR

RC TOP

	14001-PGAR
	14001-POAB
	14001-PBBN
	14001-PNBG
	14001-PAAO

ADRENALINE PROFI

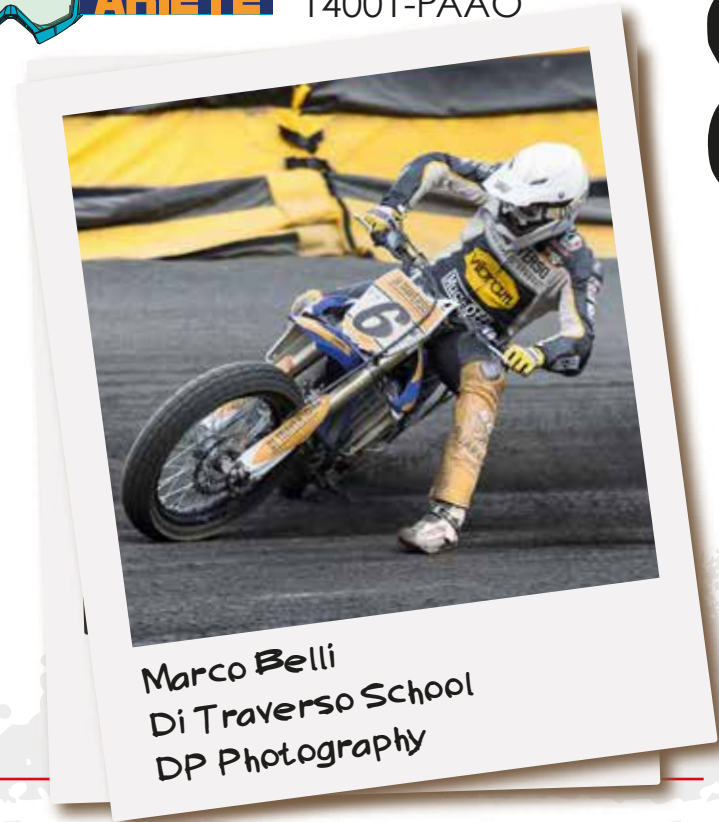

Marco Belli  
Di Traverso School  
DP Photography

# FRIENDS

# ARIEF



Isabella Otero  
photo Graham



Kevin Horgmo  
photo Horgmo Motocross



Victor Guerrero  
photo D. Agrati



CEK Alberto Cecotti  
Backstage InSella



Christopher Valente  
photo S. Taglioni



Compalati-Piana  
photo F. Crocco



Leobruno Di Biase  
photo D+M Art



Andrea Viano  
photo D.Cherubin



Francesco Muratori  
photo M.Peruzzo



Luca Sotini + Bianca Emme  
Photo StuntHeart



Jamie McCanney  
photo D.Agrati



Pol Ücar  
photo A.Ücar

# FRIENDS

# ARLEN



MX TRAINER  
The War of Riders



R.Poggiali-M.Lardori  
Quad Evolution Team



Andres Benenaula  
MR Motorcycle



Ian Salazar  
Photo J.A.Garcia Arevalo



Angelo Gambino  
Photo Mario Roten



Marcello Brignoli  
Team Rosso e Nero

**Harri's**<sup>®</sup>

**Ariete**<sup>®</sup>

**ARI**<sup>®</sup>  
THE ORIGINAL  
FORK OIL SEALS



are the trademarks of

**SANDRO MENTASTI S.R.L.**

Via Giovanni Macchi, 30 - 21100 Varese - Italy  
Tel. +39 0332 310100 - Fax +39 0332 312632

Copyright©  
Sandro Mentasti s.r.l.

[www.ariete.com](http://www.ariete.com) - [www.mentasti.com](http://www.mentasti.com) - [info@ariete.com](mailto:info@ariete.com)



Graphic Designer [www.vanhoffen.it](http://www.vanhoffen.it)

Still life [www.andreaangeluccifotografo.jimdo.com](http://www.andreaangeluccifotografo.jimdo.com)

Photo pag. 12 - 14 - 16 - 18 - 20 - 22 - 24 - 52 - 70 - 72 Allegra Marè

Stampa Euroteam Brescia

f Ariete  
@ariete\_official



Copyright©  
Sandro Mentasti s.r.l.



[www.ariete.com](http://www.ariete.com) - [www.mentasti.com](http://www.mentasti.com) - [info@ariete.com](mailto:info@ariete.com)



All rights reserved. No part of this book may be reproduced or transmitted in any form or by any means, electronic or mechanical, including photocopying, recording or by any information storage or retrieval system without permission in writing from Sandro Mentasti s.r.l.